



#### CAMPO DELLE PRESTAZIONI

- Portata fino a **6000 l/min** (360 m<sup>3</sup>/h)
- Prevalenza fino a **95 m**

#### LIMITI D'IMPIEGO

- Altezza d'aspirazione manometrica fino a **7 m**
- Temperatura del liquido da **-10 °C** fino a **+90 °C**
- Temperatura ambiente da **-10 °C** fino a **+40 °C**
- Pressione max. nel corpo pompa **10 bar** (PN10)
- Servizio continuo **S1**

#### ESECUZIONE E NORME DI SICUREZZA

EN 60034-1  
IEC 60034-1  
CEI 2-3



Dimensioni corpo pompa secondo: **EN 733**

#### CERTIFICAZIONI



#### UTILIZZI E INSTALLAZIONI

- Approvvigionamento idrico
- Pressurizzazione
- Irrigazione
- Circolazione acqua in impianti di climatizzazione
- Impianti di lavaggio
- Impianti antincendio
- Industria
- Agricoltura

L'installazione è da effettuarsi in luoghi chiusi o comunque protetti dalle intemperie.

#### ESECUZIONI A RICHIESTA

- Tenuta meccanica speciale
- Altre tensioni o frequenza a 60 Hz
- Per liquidi con temperature più alte o più basse
- Per ambienti con temperature più alte o più basse

#### GARANZIA

2 anni secondo le nostre condizioni generali di vendita

**CAMPO DI PRESTAZIONI**

**50 Hz n= 2900 1/min HS= 0 m**

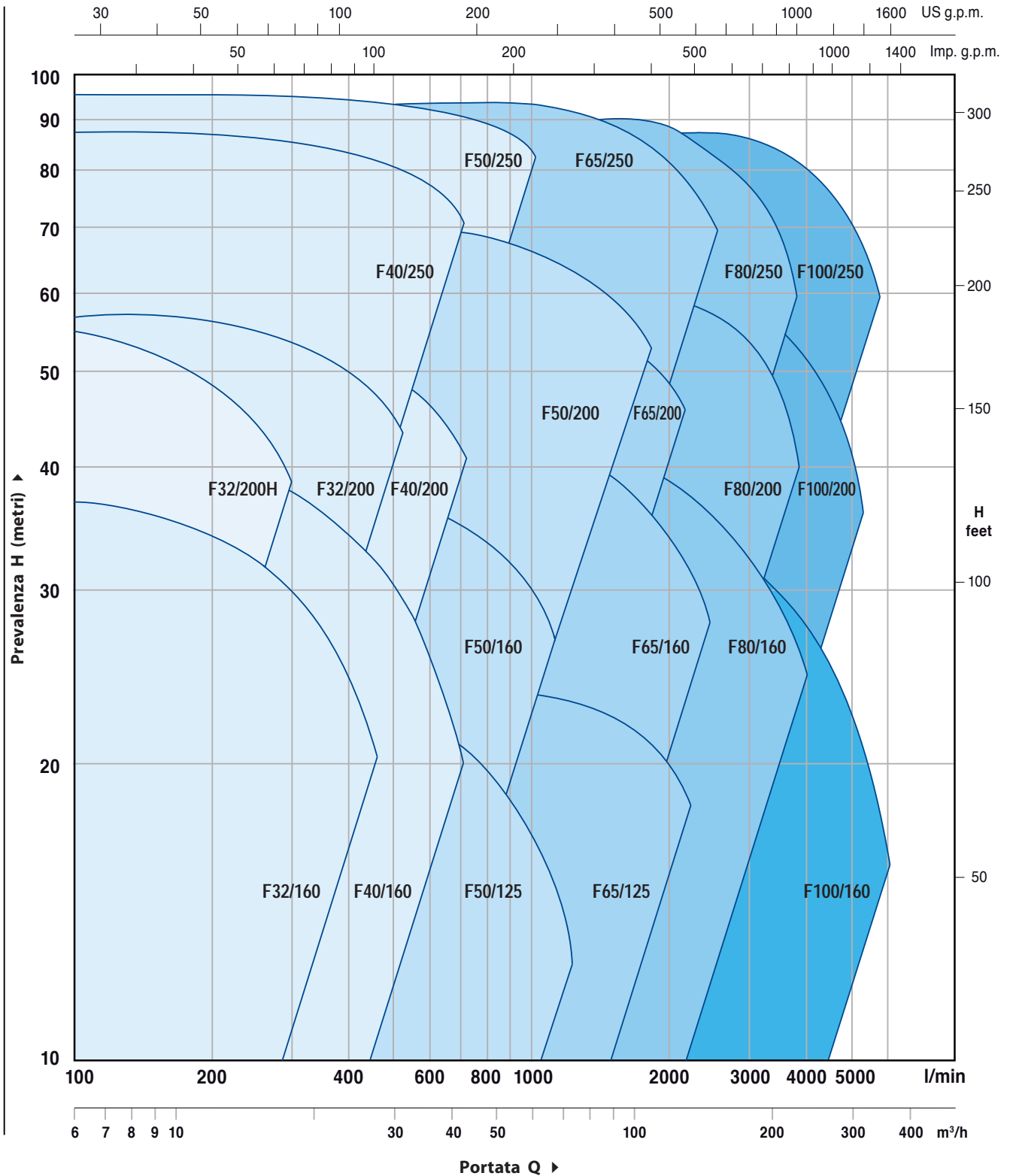

# F32/160

## CURVE E DATI DI PRESTAZIONE

50 Hz n= 2900 1/min HS= 0 m

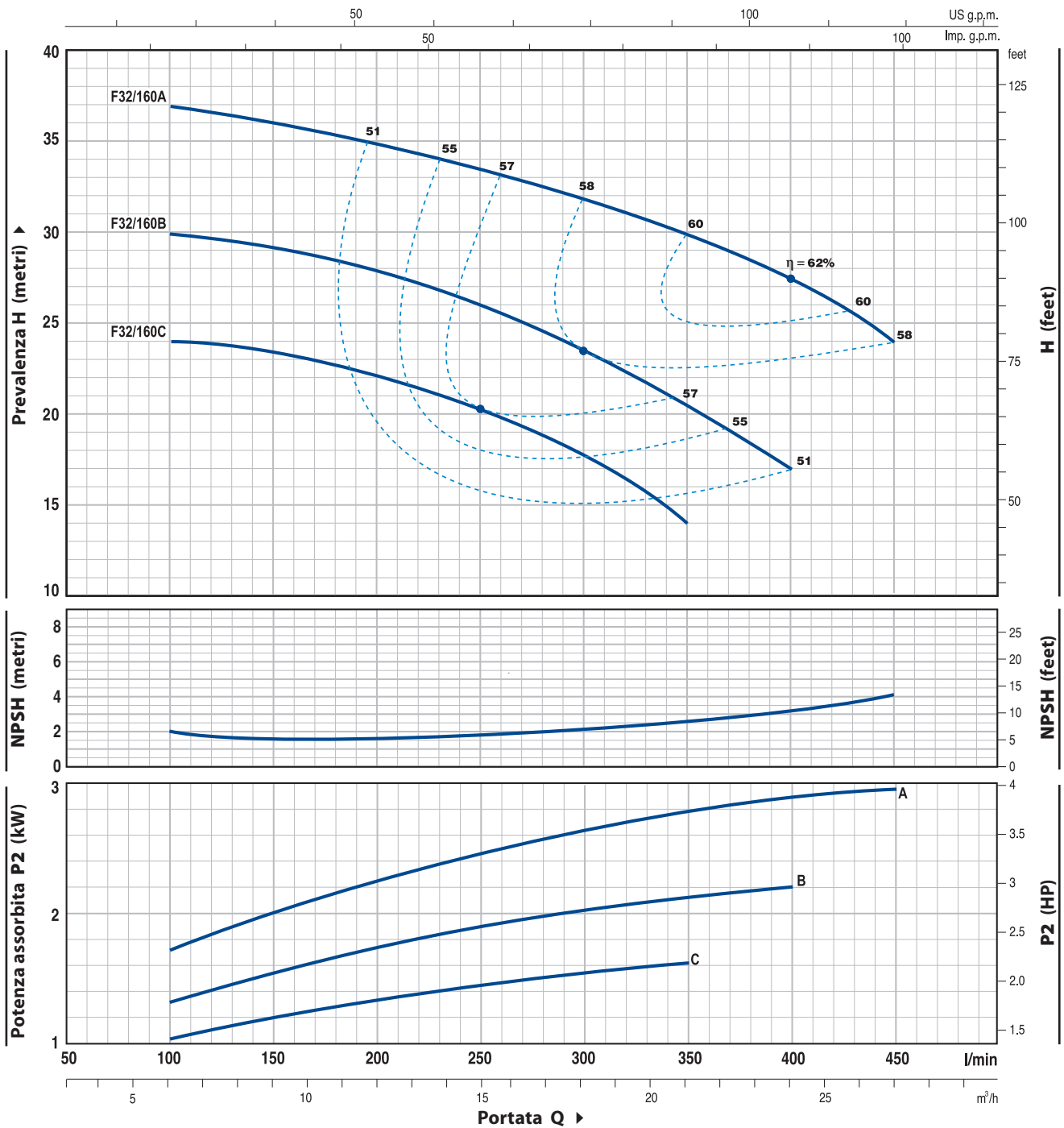

TIPO		POTENZA		Q	0	6	9	12	15	18	21	24	27
Monofase	Trifase	kW	HP		0	100	150	200	250	300	350	400	450
-	<b>F 32/160C</b>	1.5	2	H metri	25	24	23.5	22	20.5	18	14		
<b>Fm 32/160B</b>	<b>F 32/160B</b>	2.2	3		31	30	29	28	26	23.5	20.5	17	
-	<b>F 32/160A</b>	3	4		38	37	36	35	33.5	31.5	30	27.5	24

Q = Portata H = Prevalenza manometrica totale HS = Altezza di aspirazione

Tolleranza delle curve di prestazione secondo EN ISO 9906 App. A.

## CURVE E DATI DI PRESTAZIONE

50 Hz n= 2900 1/min HS= 0 m

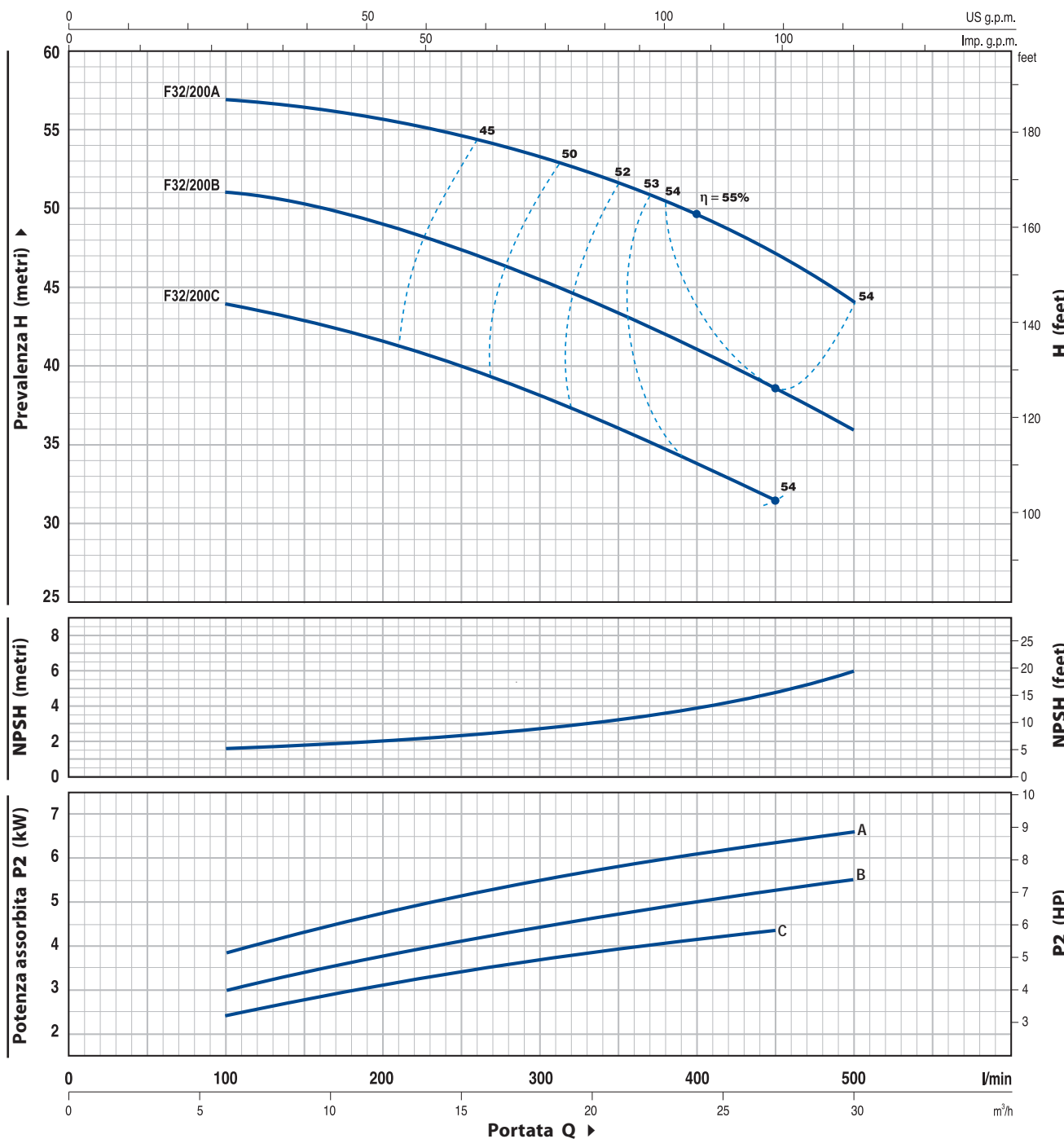

TIPO	POTENZA		Q	0	6	9	12	15	18	21	24	27	30
	kW	HP		0	100	150	200	250	300	350	400	450	500
Trifase			H metri	46	44	43	41.5	40	38	36	34	31.5	
<b>F 32/200C</b>	4	5.5		52	51	50.5	49	47	45	43	41	38.5	36
<b>F 32/200B</b>	5.5	7.5		60	57	56.5	56	55	53.5	52	50	47	44

Q = Portata H = Prevalenza manometrica totale HS = Altezza di aspirazione

Tolleranza delle curve di prestazione secondo EN ISO 9906 App. A.

# F32/200H

## CURVE E DATI DI PRESTAZIONE

50 Hz n= 2900 1/min HS= 0 m

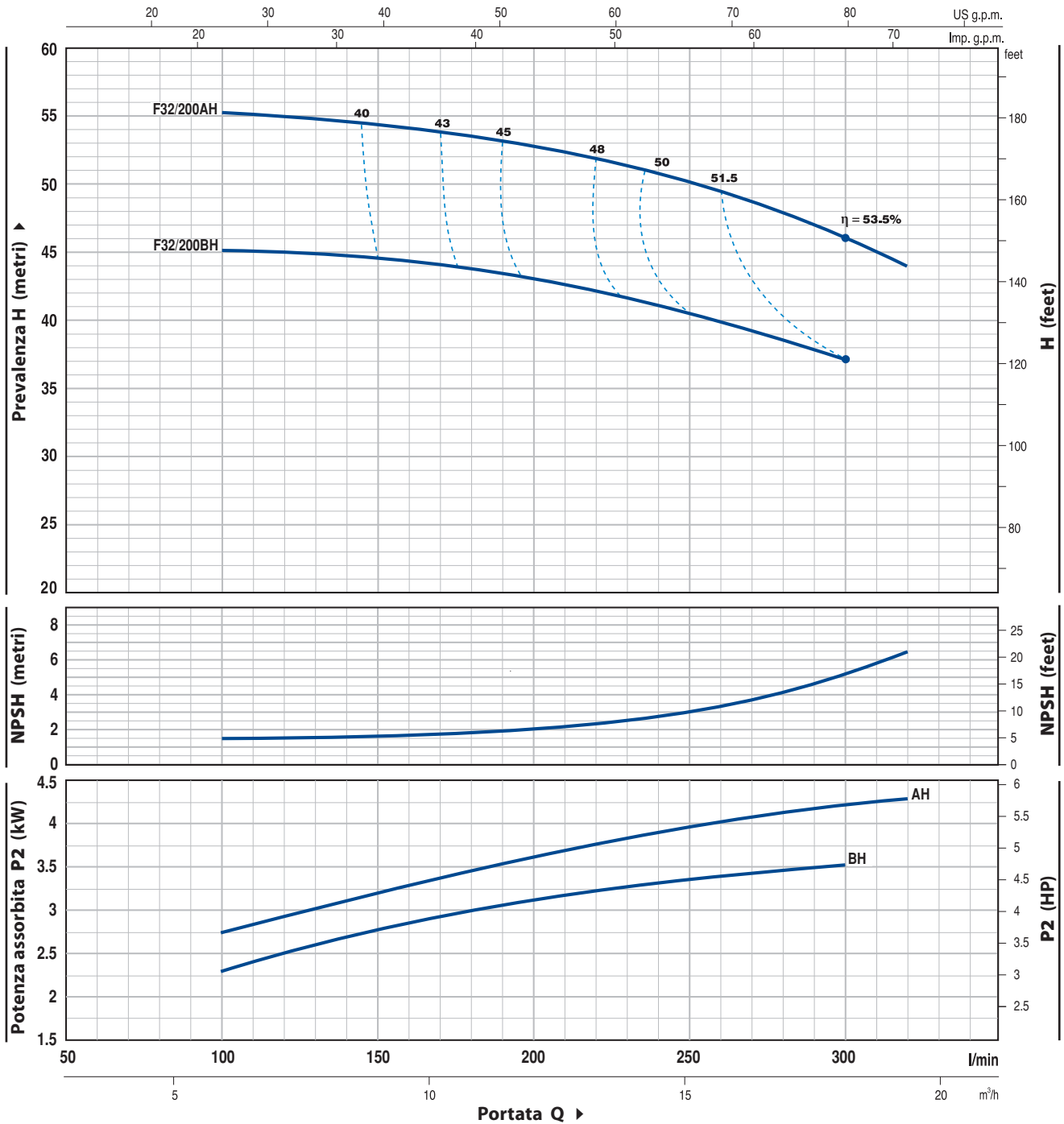

TIPO	POTENZA		Q	H						
	kW	HP		m³/h	l/min	metri	feet	HP		
Trifase				0	6	9	12	15	18	19.2
<b>F 32/200BH</b>	3	4		<b>0</b>	<b>100</b>	<b>150</b>	<b>200</b>	<b>250</b>	<b>300</b>	<b>320</b>
<b>F 32/200AH</b>	4	5.5								

Q = Portata H = Prevalenza manometrica totale HS = Altezza di aspirazione

Tolleranza delle curve di prestazione secondo EN ISO 9906 App. A.

## CURVE E DATI DI PRESTAZIONE

50 Hz n= 2900 1/min HS= 0 m

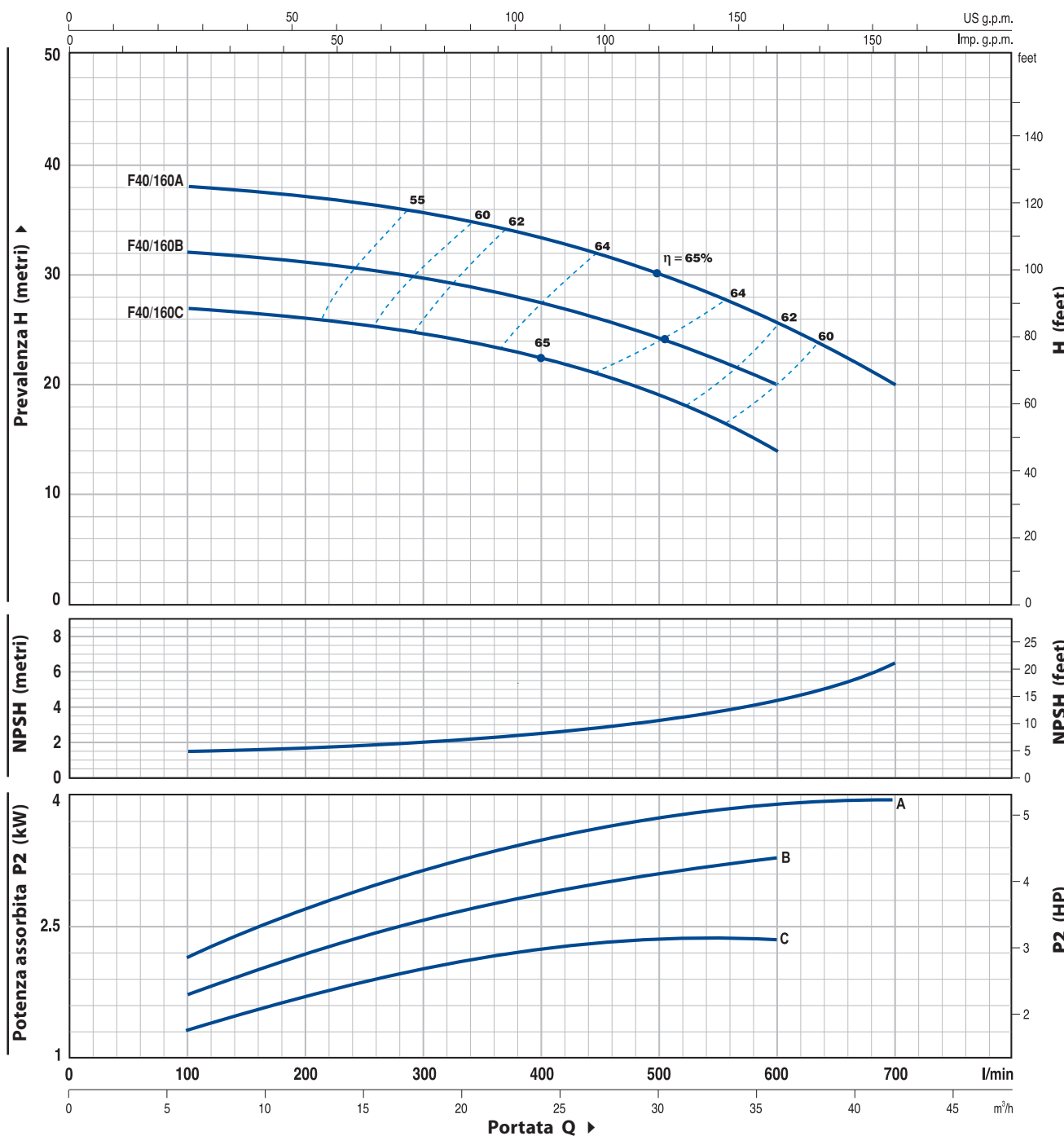

TIPO		POTENZA		Q	m³/h													
Monofase	Trifase	kW	HP		0	6	9	12	15	18	24	30	36	42				
Fm 40/160C	F 40/160C	2.2	3	H metri	0	100	150	200	250	300	400	500	600	700				
-	F 40/160B	3	4		27	27	26.5	26	25.5	25	22.5	19	14					
-	F 40/160A	4	5.5		32	32	31.5	31	30.5	30	27.5	24	20					
					38	38	37.8	37	36.5	36	33.5	30	26	20				

Q = Portata H = Prevalenza manometrica totale HS = Altezza di aspirazione

Tolleranza delle curve di prestazione secondo EN ISO 9906 App. A.

# F40/200

## CURVE E DATI DI PRESTAZIONE

50 Hz n= 2900 1/min HS= 0 m

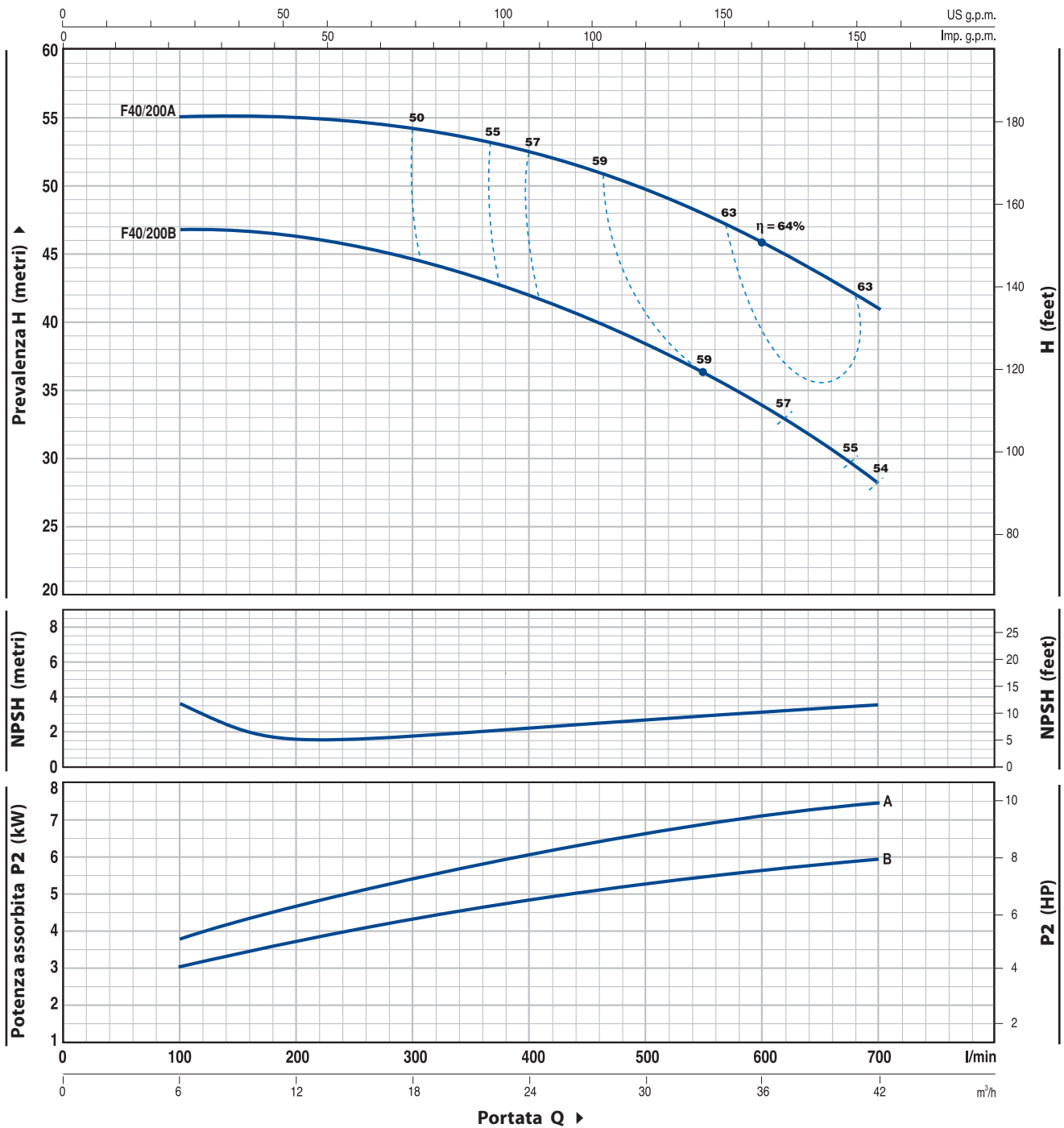

TIPO	POTENZA		Q	Portata Q												
	kW	HP		0	6	9	12	15	18	24	30	36	42			
Trifase			Q	0	100	150	200	250	300	400	500	600	700			
<b>F 40/200B</b>	5.5	7.5	H metri	48	47	46.5	46	45.5	44.5	42	38	34	28			
<b>F 40/200A</b>	7.5	10		56	55	55	55	54.5	54	52.5	49.5	46	41			

Q = Portata H = Prevalenza manometrica totale HS = Altezza di aspirazione

Tolleranza delle curve di prestazione secondo EN ISO 9906 App. A.

## CURVE E DATI DI PRESTAZIONE

50 Hz n= 2900 1/min HS= 0 m

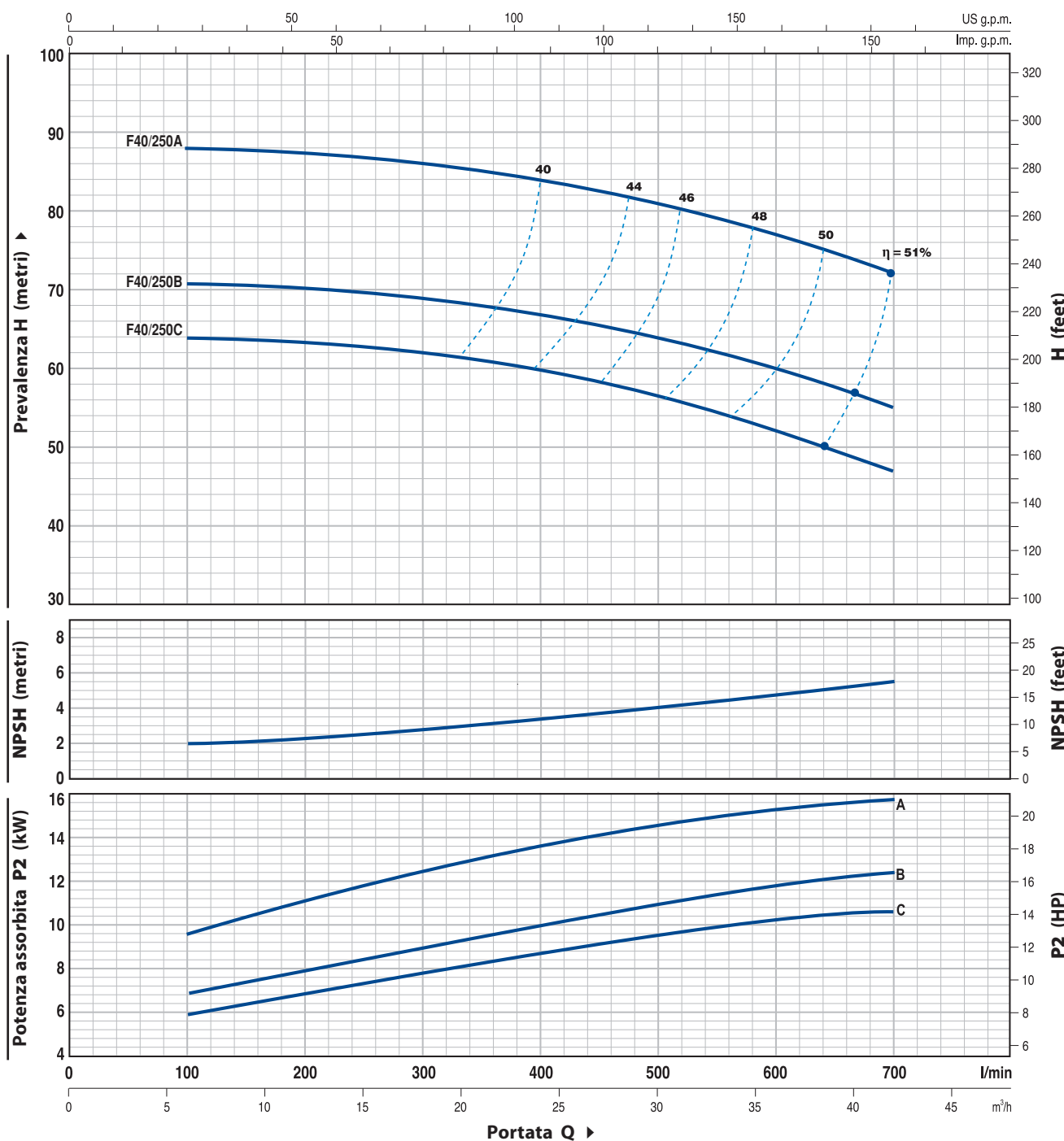

TIPO	POTENZA		Q	0	6	9	12	15	18	24	30	36	42
	kW	HP		0	100	150	200	250	300	400	500	600	700
Trifase			H metri	64	64	63.5	63	62.5	62	60	56.5	52.5	47
<b>F 40/250C</b>	9.2	12.5		71	71	70.5	70	69.5	69	67	64	60	55
<b>F 40/250B</b>	11	15		88	88	87.5	87	86.5	86	84	81	77	72

Q = Portata H = Prevalenza manometrica totale HS = Altezza di aspirazione

Tolleranza delle curve di prestazione secondo EN ISO 9906 App. A.



# F50/125

## CURVE E DATI DI PRESTAZIONE

50 Hz n= 2900 1/min HS= 0 m

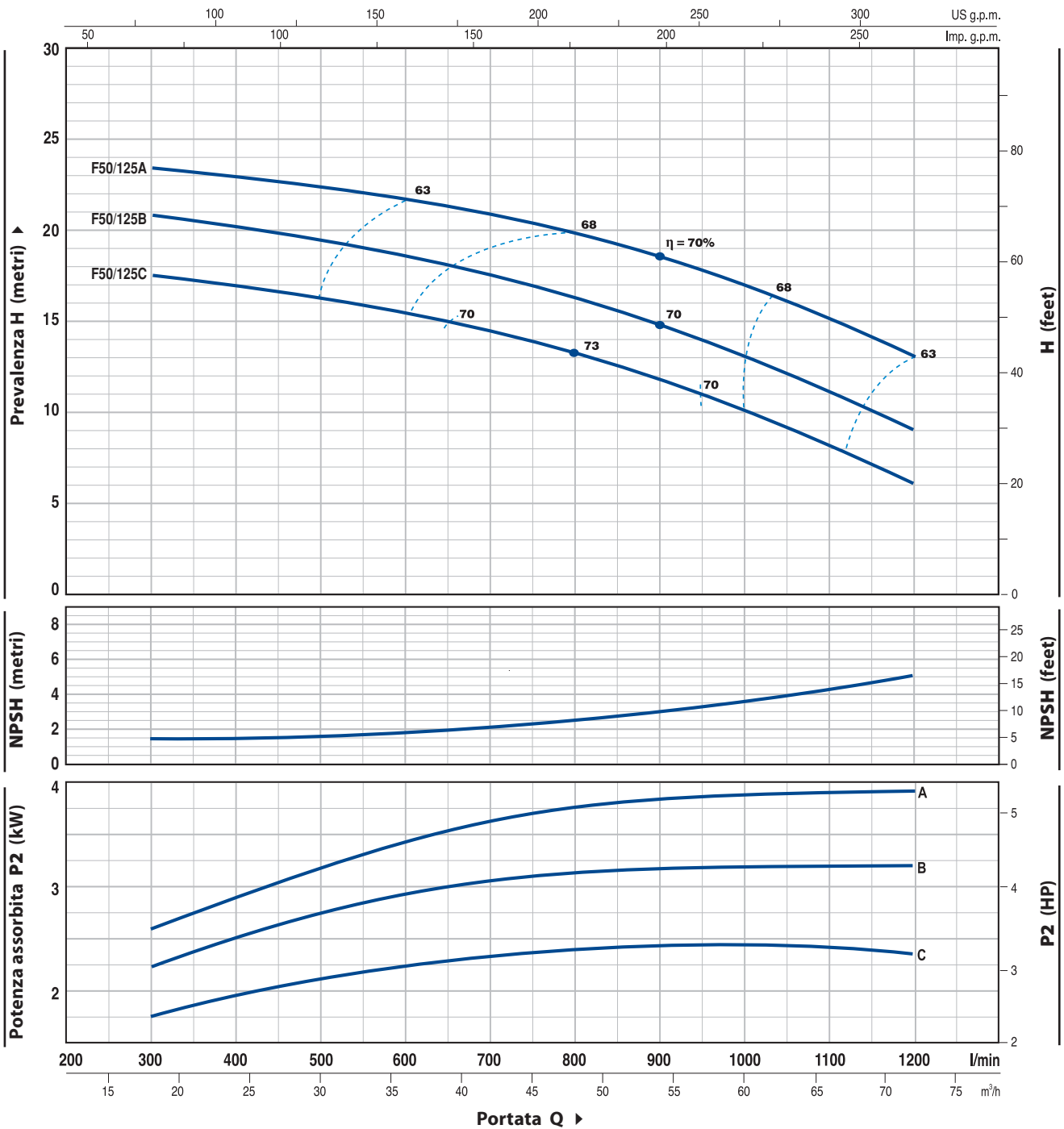

TIPO		POTENZA		Q	Flow Rate (Q)													
Monofase	Trifase	kW	HP		0	18	24	30	36	42	48	54	60	66	72			
Fm 50/125C	F 50/125C	2.2	3	H metri	18.5	17.5	17	16.5	15.5	14.8	13.5	12	10.5	8.2	6			
-	F 50/125B	3	4		21.5	20.7	20	19.5	18.8	17.8	16.5	15	13.5	11.2	9			
-	F 50/125A	4	5.5		24.5	23.5	23	22.5	21.8	20.8	19.5	18.3	16.8	15	13			

Q = Portata H = Prevalenza manometrica totale HS = Altezza di aspirazione

Tolleranza delle curve di prestazione secondo EN ISO 9906 App. A.

## CURVE E DATI DI PRESTAZIONE

50 Hz n= 2900 1/min HS= 0 m

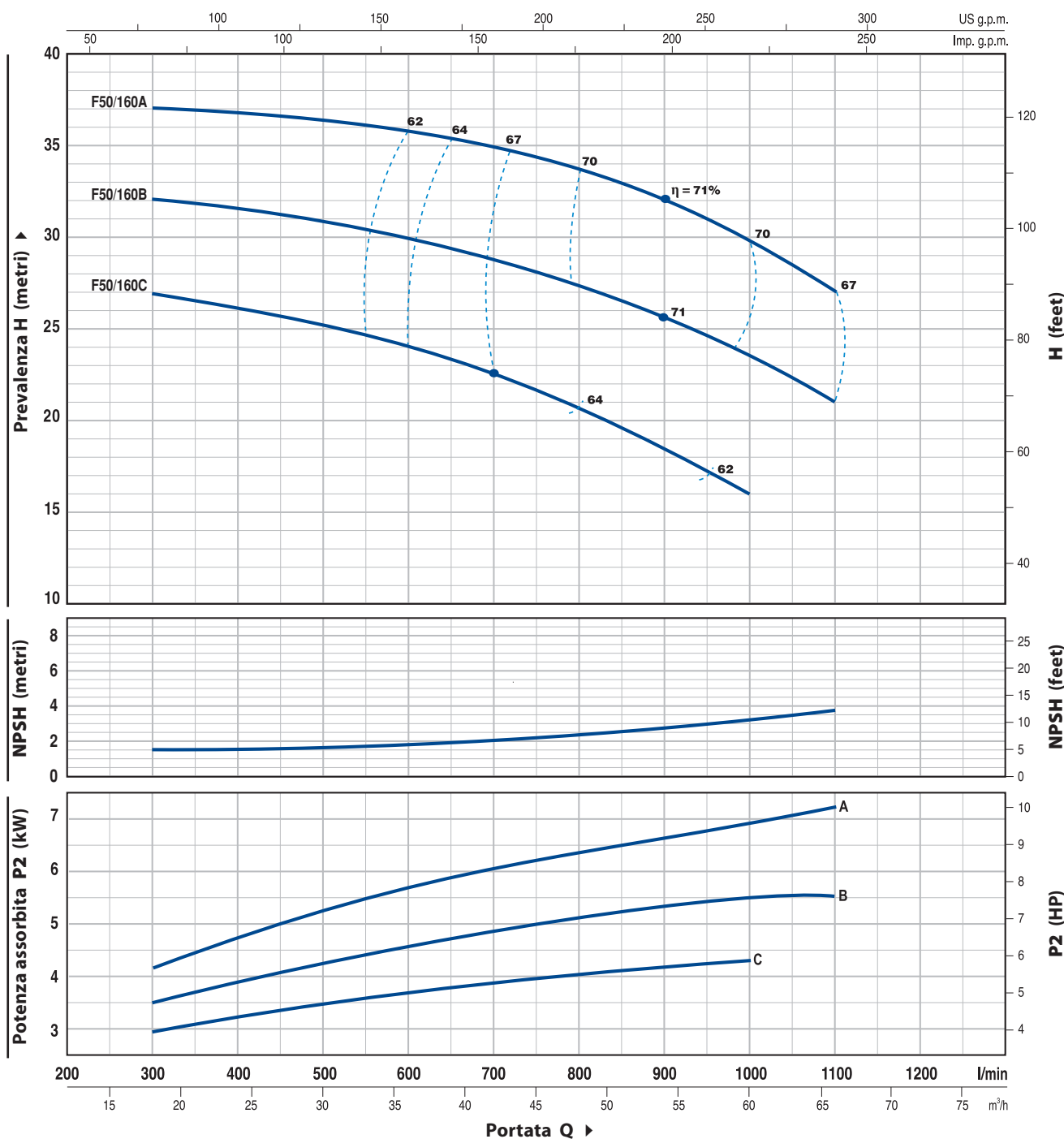

TIPO	POTENZA		Q	0	18	24	30	36	42	48	54	60	66
	kW	HP		0	300	400	500	600	700	800	900	1000	1100
Trifase			H metri										
<b>F 50/160C</b>	4	5.5		27	27	26.5	25	24.5	23	20	18.5	16	
<b>F 50/160B</b>	5.5	7.5		33	32	31.7	31	30	29	27	26	24	21
<b>F 50/160A</b>	7.5	10		38	37	36.8	36.5	36	34	33	32	30	27

Q = Portata H = Prevalenza manometrica totale HS = Altezza di aspirazione

Tolleranza delle curve di prestazione secondo EN ISO 9906 App. A.

# F50/200

## CURVE E DATI DI PRESTAZIONE

50 Hz n= 2900 1/min HS= 0 m

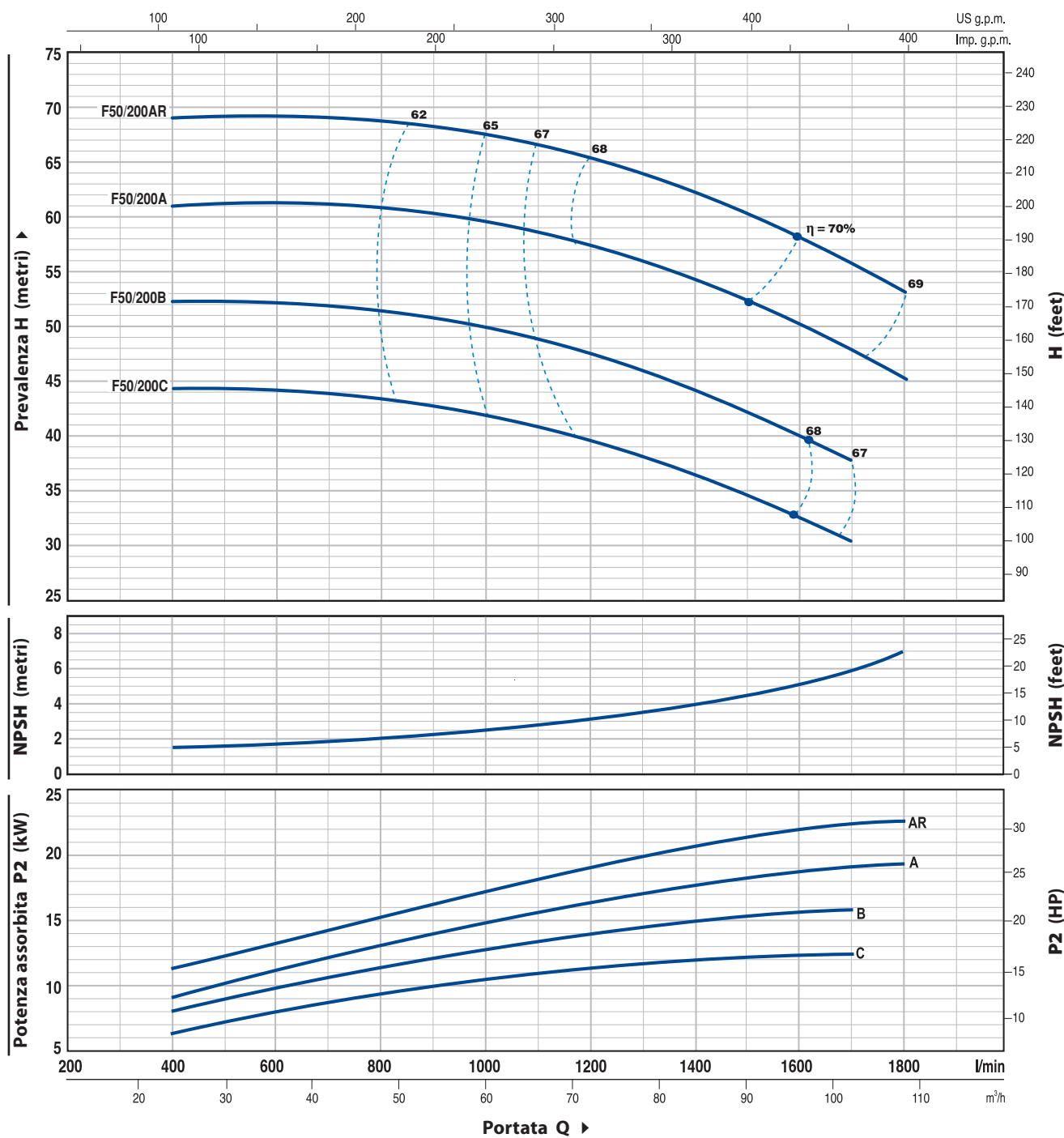

TIPO	POTENZA		Q	24	36	48	60	72	84	96	102	108
	kW	HP		400	600	800	1000	1200	1400	1600	1700	1800
Trifase			H metri	44	44	44	42	39	36	33	30	
<b>F 50/200C</b>	11	15		52	52	52	50	47	44	40	38	
<b>F 50/200B</b>	15	20		61	61	60.5	60	57	54	50	48	45
<b>F 50/200A</b>	18.5	25		69	69	68.5	68	65	62	58	56	53
<b>F 50/200AR</b>	22	30										

Q = Portata H = Prevalenza manometrica totale HS = Altezza di aspirazione

Tolleranza delle curve di prestazione secondo EN ISO 9906 App. A.

## CURVE E DATI DI PRESTAZIONE

50 Hz n= 2900 1/min HS= 0 m

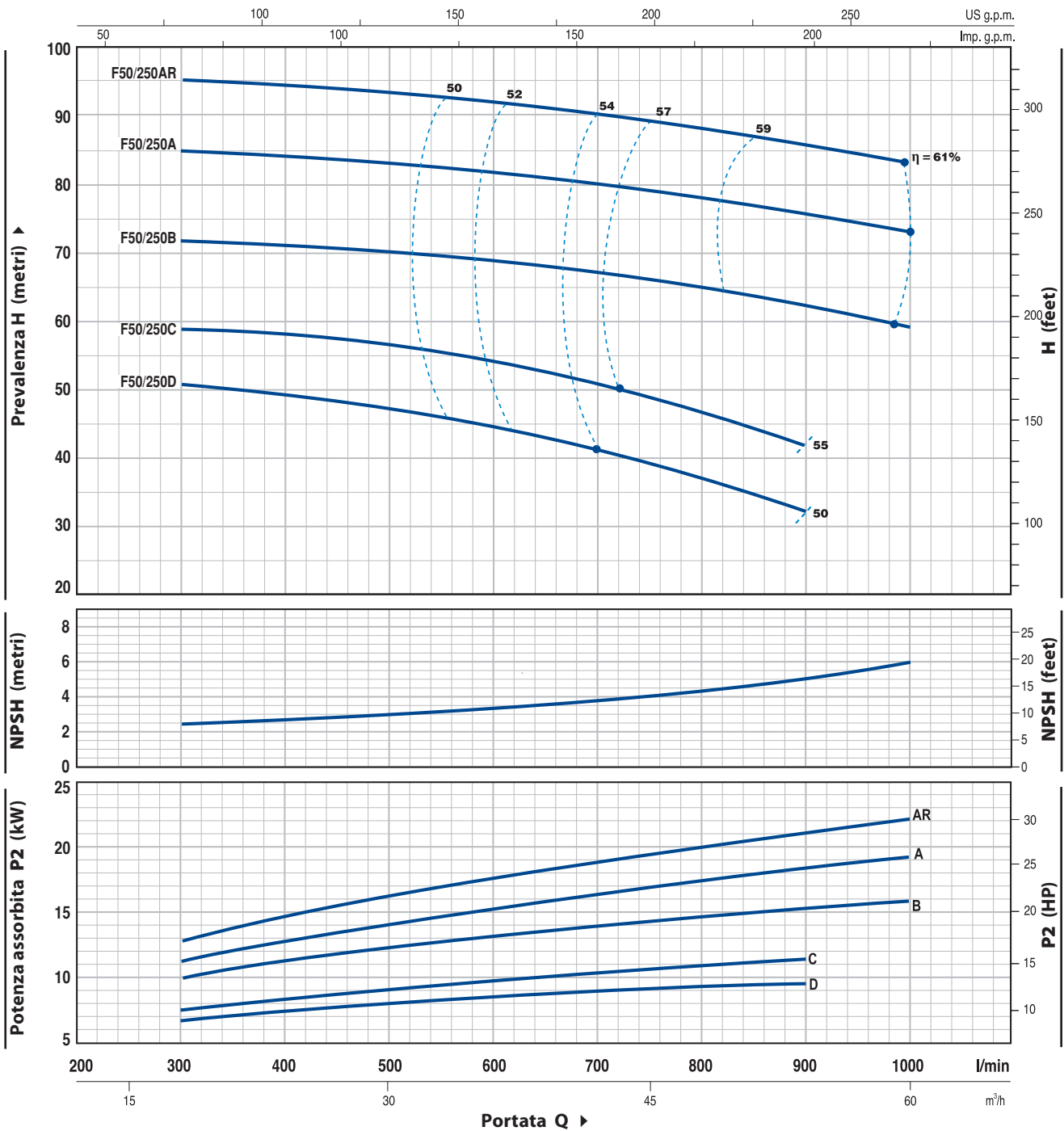

TIPO	POTENZA		Q	Flow Rate (Q)											
	kW	HP		0	18	24	30	36	42	48	54	60			
Trifase			l/min	0	300	400	500	600	700	800	900	1000			
F 50/250D	9.2	12.5	H metri	51	51	49	47	44	41	37	32				
F 50/250C	11	15		59	59	58	57	54	51	47	42				
F 50/250B	15	20		72	72	71	70	69	67	65	62	59			
F 50/250A	18.5	25		85	85	84	83	82	80	78	76	73			
F 50/250AR	22	30		95	95	94	93	92	90	88	86	83			

Q = Portata H = Prevalenza manometrica totale HS = Altezza di aspirazione

Tolleranza delle curve di prestazione secondo EN ISO 9906 App. A.

# F65/125

## CURVE E DATI DI PRESTAZIONE

50 Hz n= 2900 1/min HS= 0 m

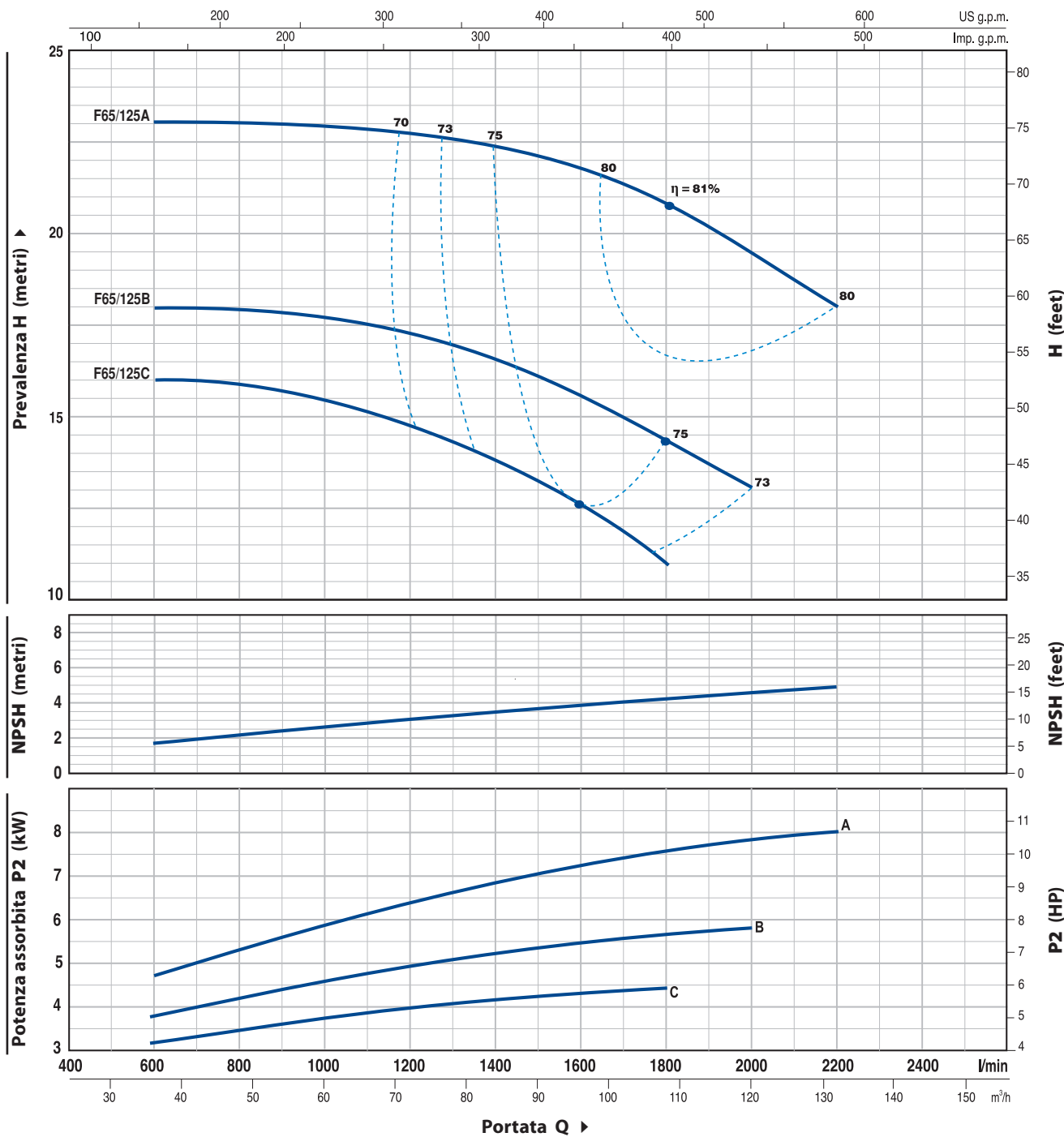

TIPO	POTENZA		Q	Flow Rate (m³/h)											
	kW	HP		0	36	48	60	72	84	96	108	120	132		
Trifase			l/min	0	600	800	1000	1200	1400	1600	1800	2000	2200		
<b>F 65/125C</b>	4	5.5	H metri	16	16	16	15.5	14.5	13.5	12.5	11				
<b>F 65/125B</b>	5.5	7.5		18	18	18	18	17	16.5	15.5	14.5	13			
<b>F 65/125A</b>	7.5	10		23	23	23	23	22.5	22.5	22	21	19.5	18		

Q = Portata H = Prevalenza manometrica totale HS = Altezza di aspirazione

Tolleranza delle curve di prestazione secondo EN ISO 9906 App. A.

## CURVE E DATI DI PRESTAZIONE

50 Hz n= 2900 1/min HS= 0 m

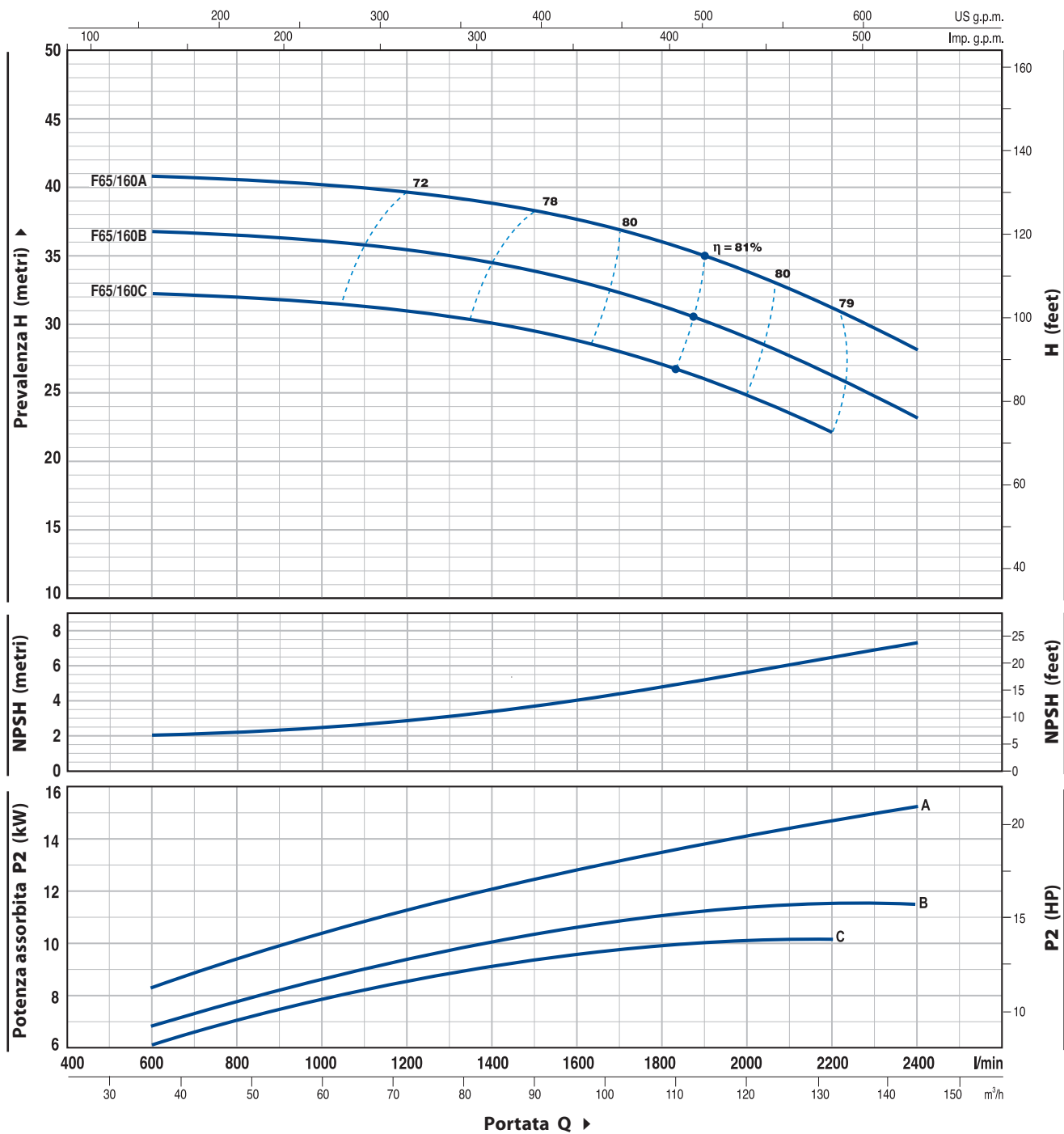

TIPO	POTENZA		Q	Flow Rate (Q)													
	kW	HP		0	36	48	60	72	84	96	108	120	132	144			
Trifase				0	600	800	1000	1200	1400	1600	1800	2000	2200	2400			
<b>F 65/160C</b>	9.2	12.5	H metri	32	32	32	32	32	30	29	27	25	22				
<b>F 65/160B</b>	11	15		37	36.5	36.5	36	35.5	34	33	31	29	26	23			
<b>F 65/160A</b>	15	20		41	40.5	40.5	40	39.5	39	37.5	36	34	31	28			

Q = Portata H = Prevalenza manometrica totale HS = Altezza di aspirazione

Tolleranza delle curve di prestazione secondo EN ISO 9906 App. A.

# F65/200

## CURVE E DATI DI PRESTAZIONE

50 Hz n= 2900 1/min HS= 0 m

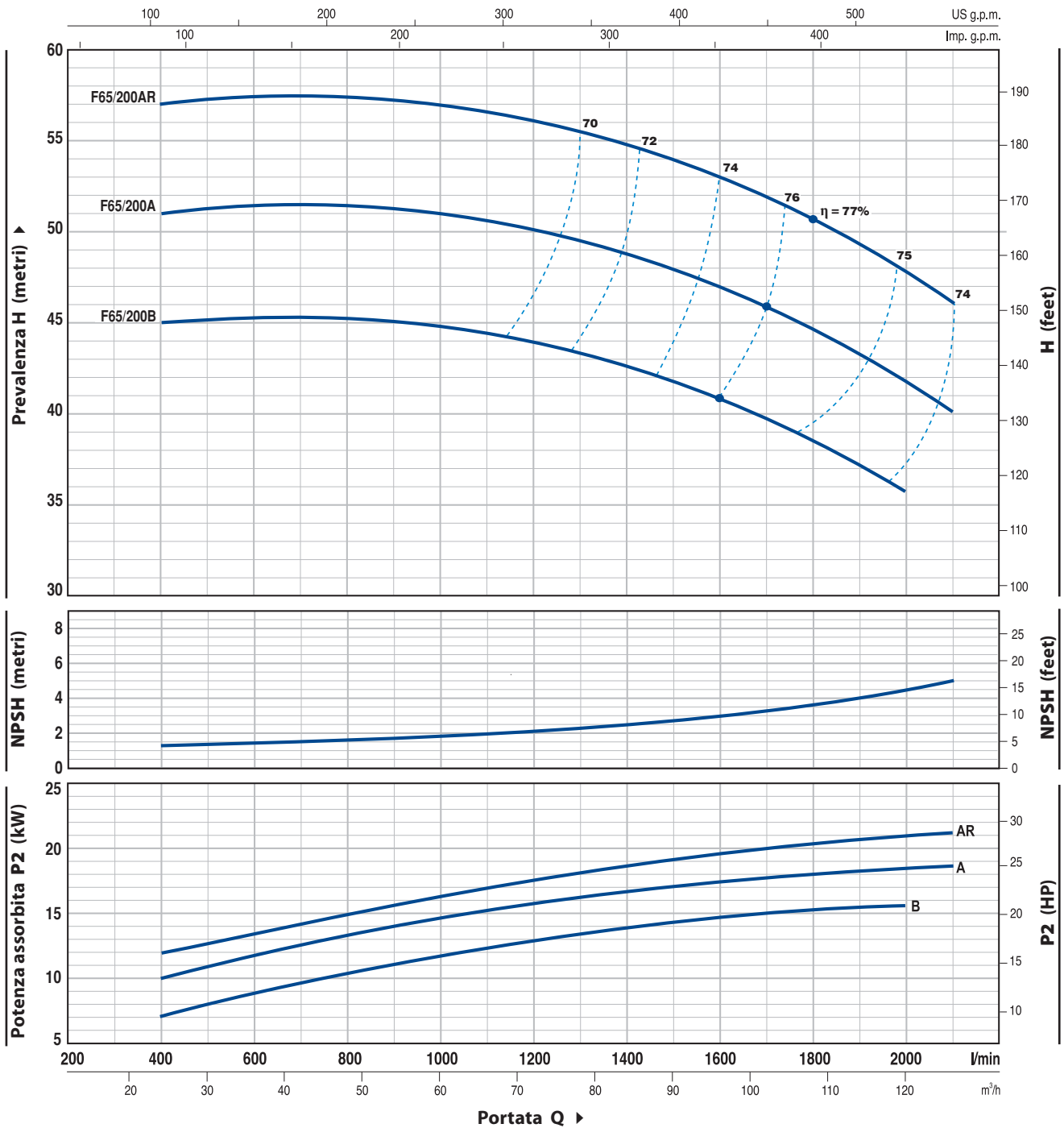

TIPO	POTENZA		Q	24	36	48	60	72	84	96	108	120	126
	kW	HP		400	600	800	1000	1200	1400	1600	1800	2000	2100
Trifase			H metri										
<b>F 65/200B</b>	15	20		45	45	45	45	44	42.5	41	38.5	35.5	
<b>F 65/200A</b>	18.5	25		51	51	51	51	50	49	47	44.5	41.5	40
<b>F 65/200AR</b>	22	30		57	57	57	57	56	55	53	50.5	47.5	46

Q = Portata H = Prevalenza manometrica totale HS = Altezza di aspirazione

Tolleranza delle curve di prestazione secondo EN ISO 9906 App. A.

## CURVE E DATI DI PRESTAZIONE

50 Hz n= 2900 1/min HS= 0 m

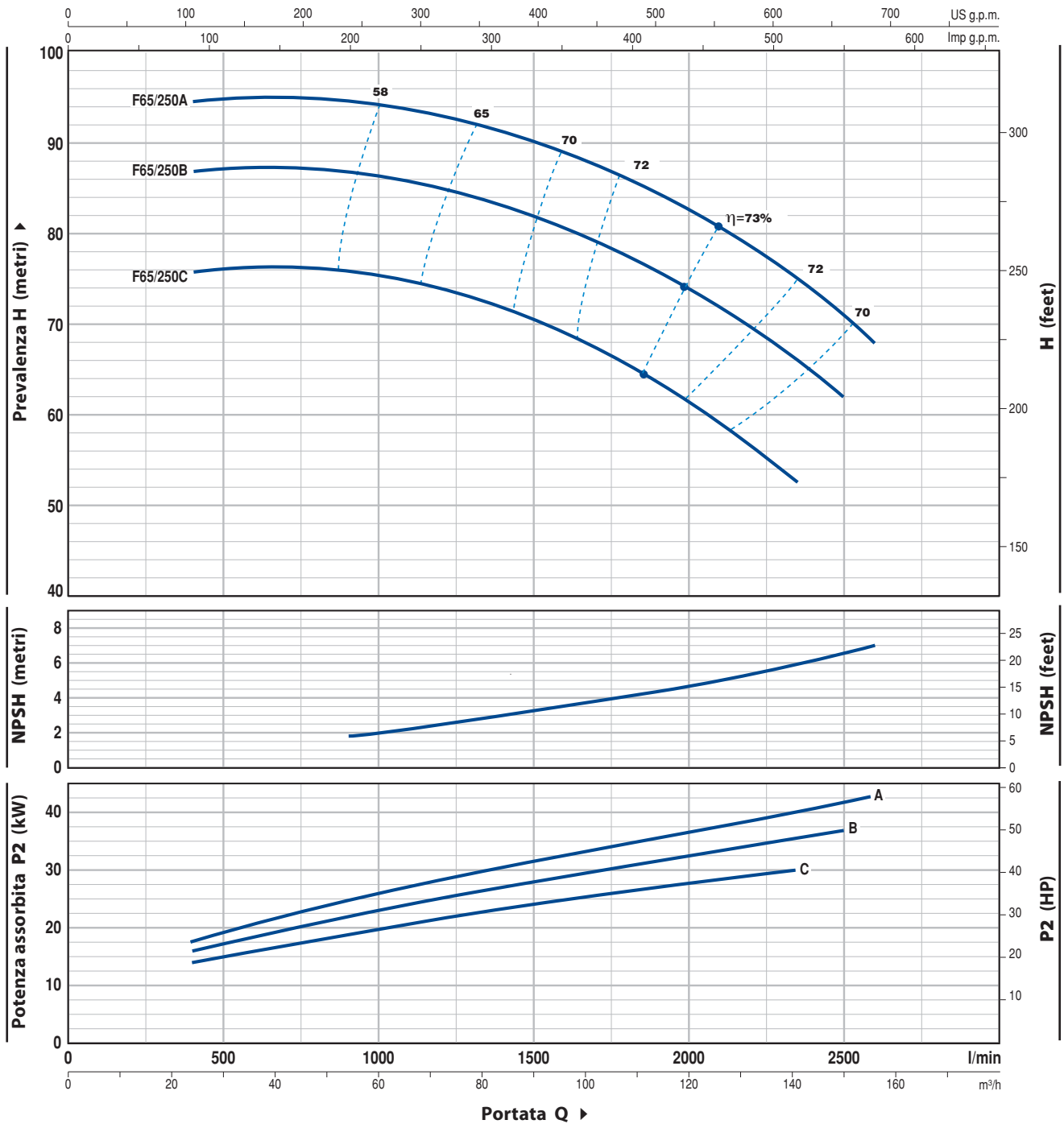

TIPO	POTENZA		Q	24	40	60	80	100	120	141	150	156
	kW	HP		m³/h	400	667	1000	1333	1667	2000	2350	2500
Trifase			H metri	76	76	75.5	72.5	68	61.5	53		
<b>F 65/250C</b>	30	40		87	87	86	84	80	74	66.5	62	
<b>F 65/250B</b>	37	50		94.5	95	94	92	88	82.5	75	71	68

Q = Portata H = Prevalenza manometrica totale HS = Altezza di aspirazione

Tolleranza delle curve di prestazione secondo EN ISO 9906 App. A.



# F80/160

## CURVE E DATI DI PRESTAZIONE

50 Hz n= 2900 1/min HS= 0 m

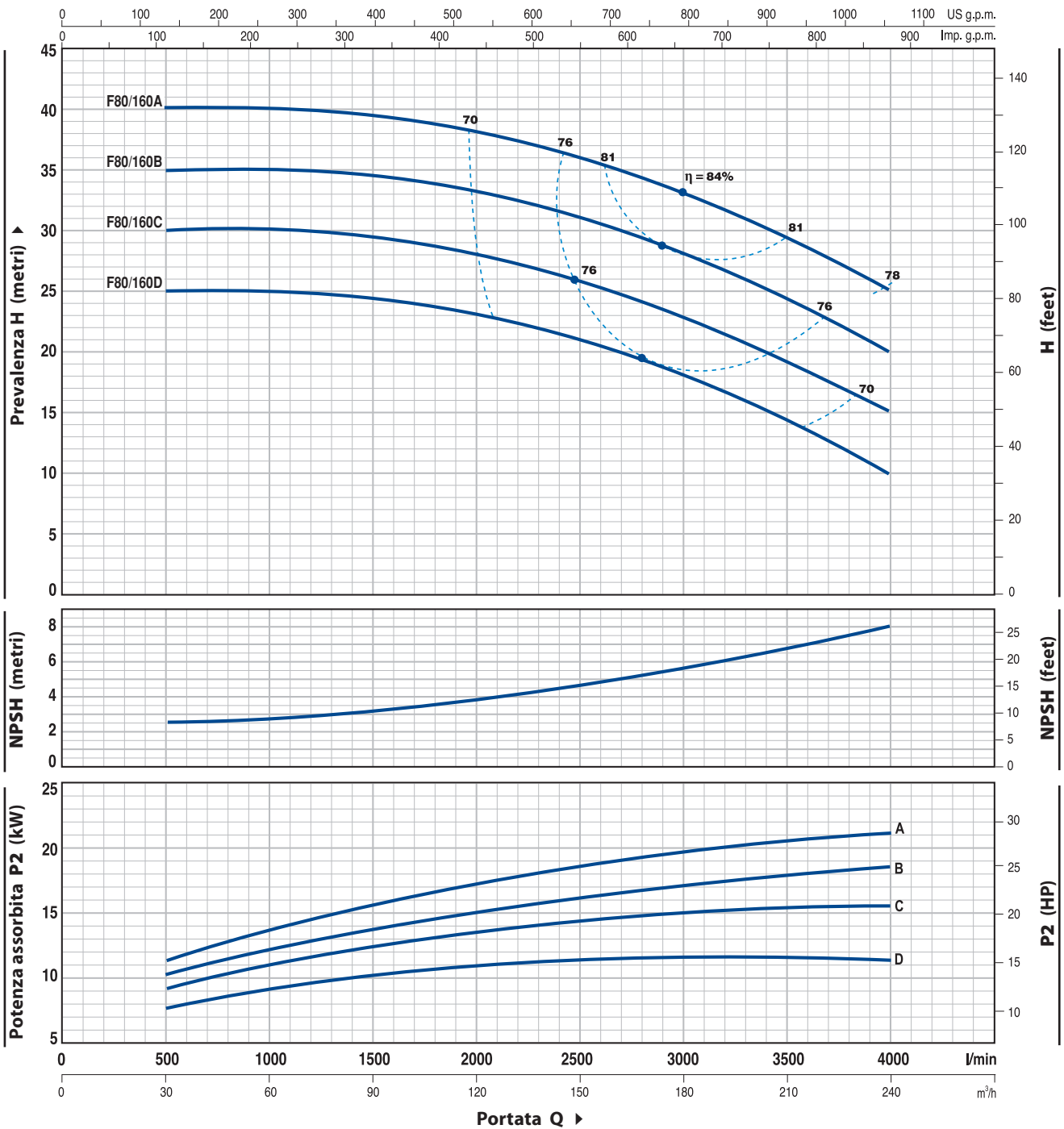

TIPO	POTENZA		Q	0	30	60	90	120	150	180	210	240
	kW	HP		0	500	1000	1500	2000	2500	3000	3500	4000
Trifase			H metri									
<b>F 80/160D</b>	11	15		25	25	25	24.5	23.5	21	18	14.5	10
<b>F 80/160C</b>	15	20		30	30	30	29.5	28.5	26	23	19.5	15
<b>F 80/160B</b>	18.5	25		35	35	35	34.5	33.5	31	28.5	24.5	20
<b>F 80/160A</b>	22	30		40	40	40	39.5	38.5	36	33	29.5	25

Q = Portata H = Prevalenza manometrica totale HS = Altezza di aspirazione

Tolleranza delle curve di prestazione secondo EN ISO 9906 App. A.

## CURVE E DATI DI PRESTAZIONE

50 Hz n= 2900 1/min HS= 0 m

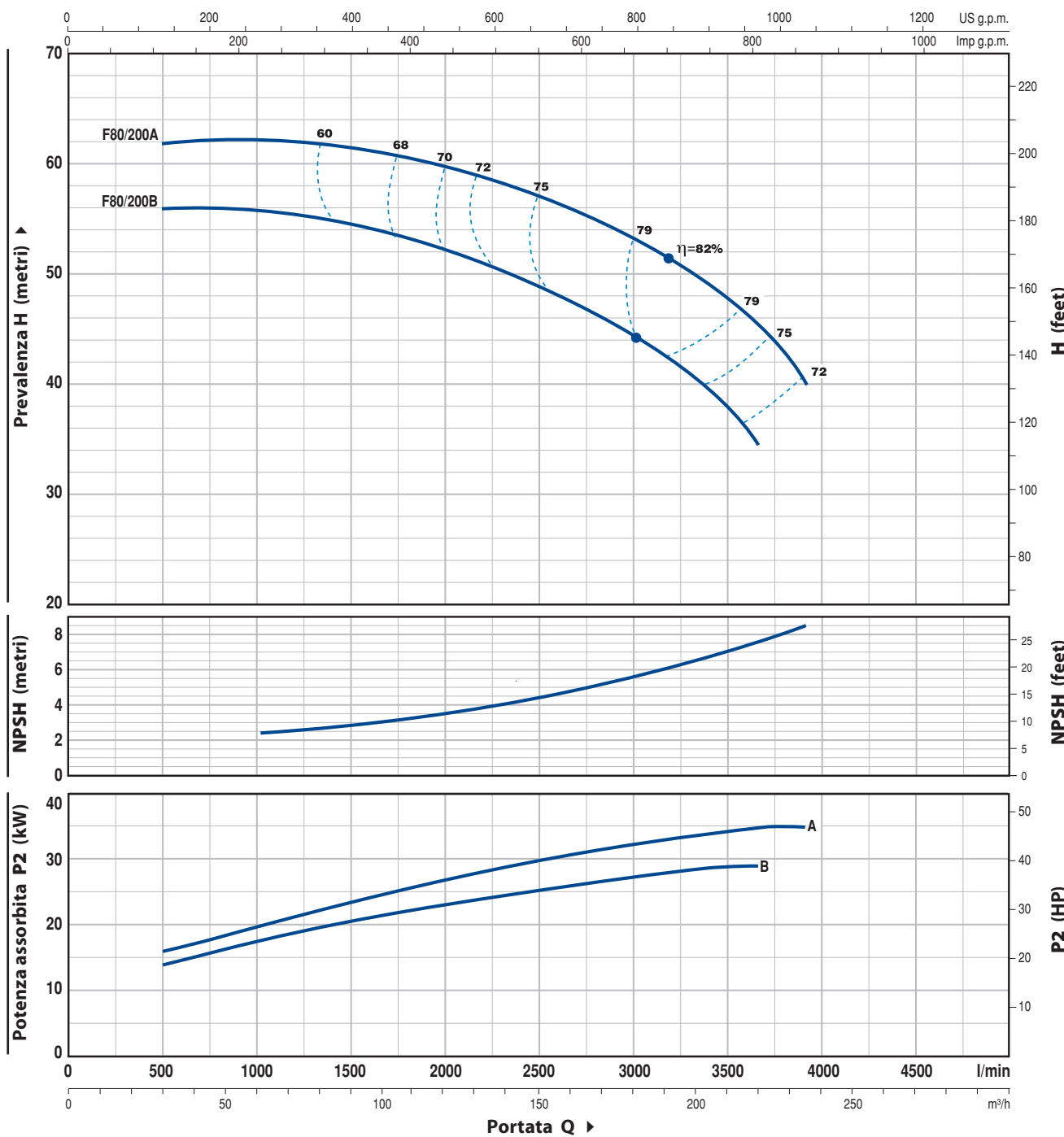

TIPO	POTENZA		Q	30	50	100	150	200	219	234
	kW	HP		l/min	500	833	1667	2500	3333	3650
Trifase			H metri	56	56	54	49	41	34.5	
<b>F 80/200B</b>	30	40		62	62	61	57	50	45.5	40
<b>F 80/200A</b>	37	50								

Q = Portata H = Prevalenza manometrica totale HS = Altezza di aspirazione

Tolleranza delle curve di prestazione secondo EN ISO 9906 App. A.

# F80/250

## CURVE E DATI DI PRESTAZIONE

50 Hz n= 2900 1/min HS= 0 m

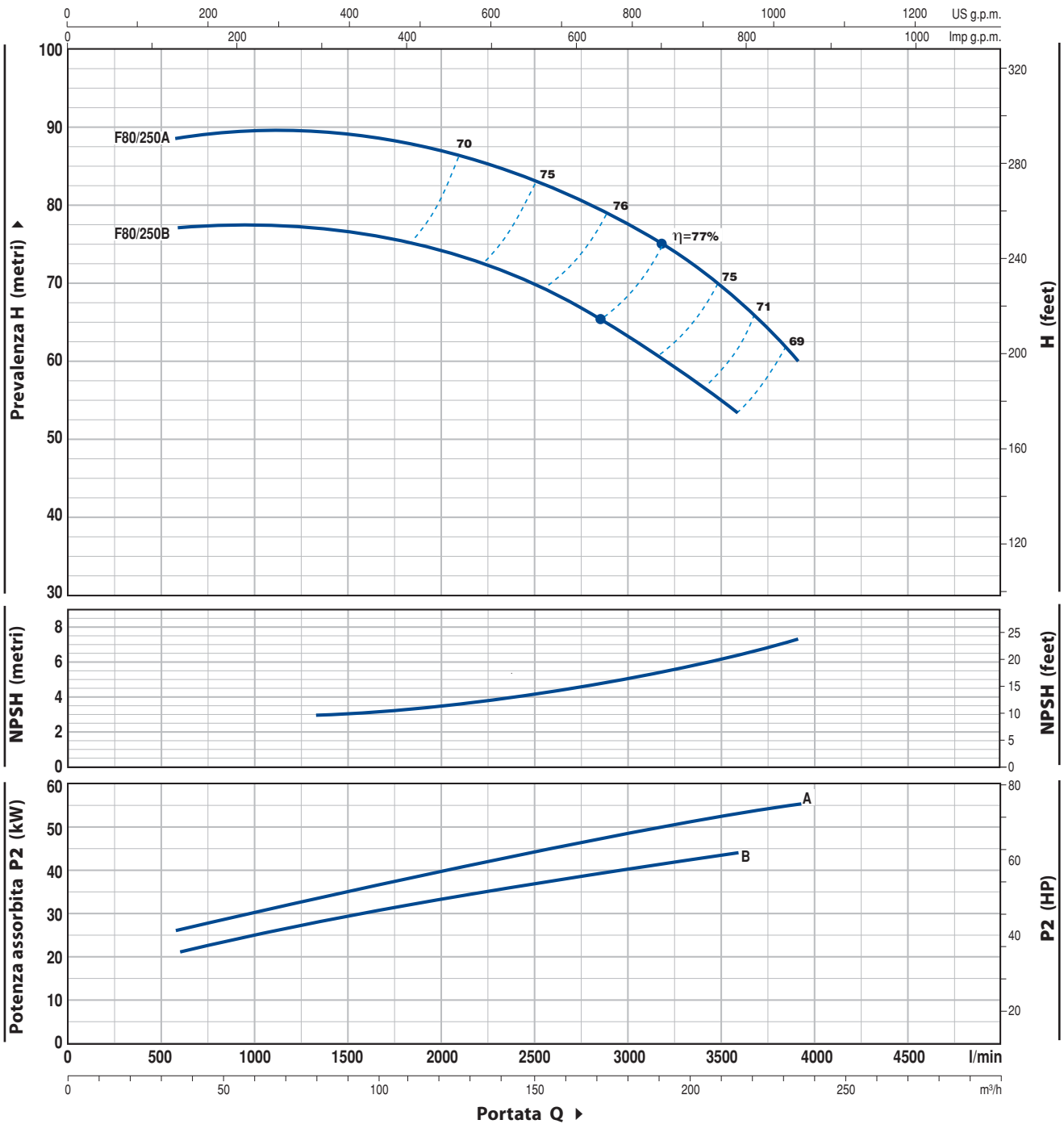

TIPO	POTENZA		Q	H metri								
	kW	HP		m³/h	l/min	36	50	100	150	200	216	234
Trifase				600	833	1667	2500	3333	3600	3900		
<b>F 80/250B</b>	45	60		77	77.5	76	70.5	58.5	54			
<b>F 80/250A</b>	55	75		88.5	89.5	89	83	72	68	60		

Q = Portata H = Prevalenza manometrica totale HS = Altezza di aspirazione

Tolleranza delle curve di prestazione secondo EN ISO 9906 App. A.

## CURVE E DATI DI PRESTAZIONE

50 Hz n= 2900 1/min HS= 0 m

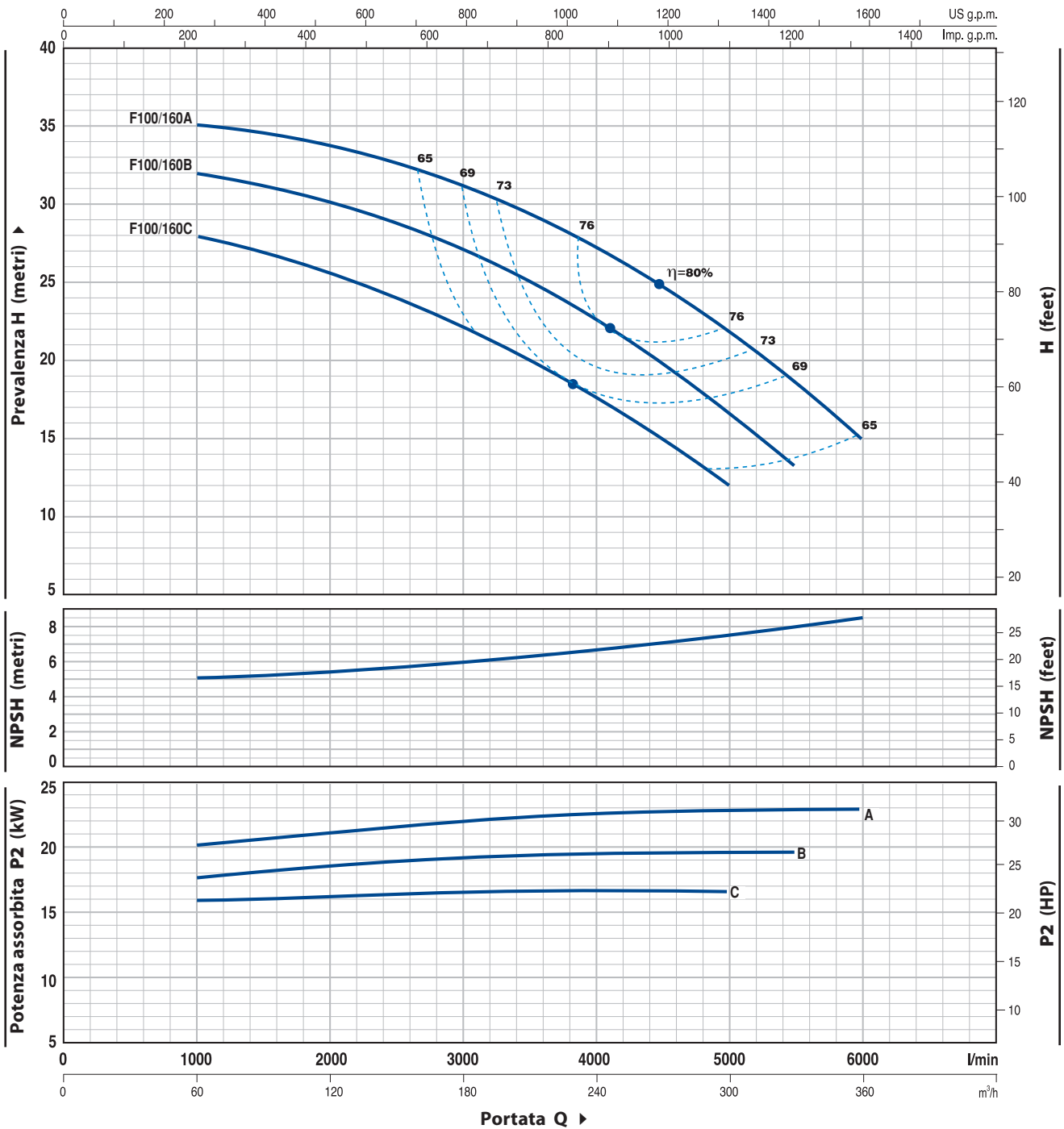

TIPO	POTENZA		Q	0	60	120	180	240	270	300	330	360
	kW	HP		0	1000	2000	3000	4000	4500	5000	5500	6000
Trifase			H metri									
<b>F 100/160C</b>	15	20		28	28	25.5	22	17.5	15	12		
<b>F 100/160B</b>	18.5	25		32	32	30	27	22.5	19.5	17	13	
<b>F 100/160A</b>	22	30		35	35	34	31	27	24.5	22	18	15

Q = Portata H = Prevalenza manometrica totale HS = Altezza di aspirazione

Tolleranza delle curve di prestazione secondo EN ISO 9906 App. A.

# F100/200

## CURVE E DATI DI PRESTAZIONE

50 Hz n= 2900 1/min HS= 0 m

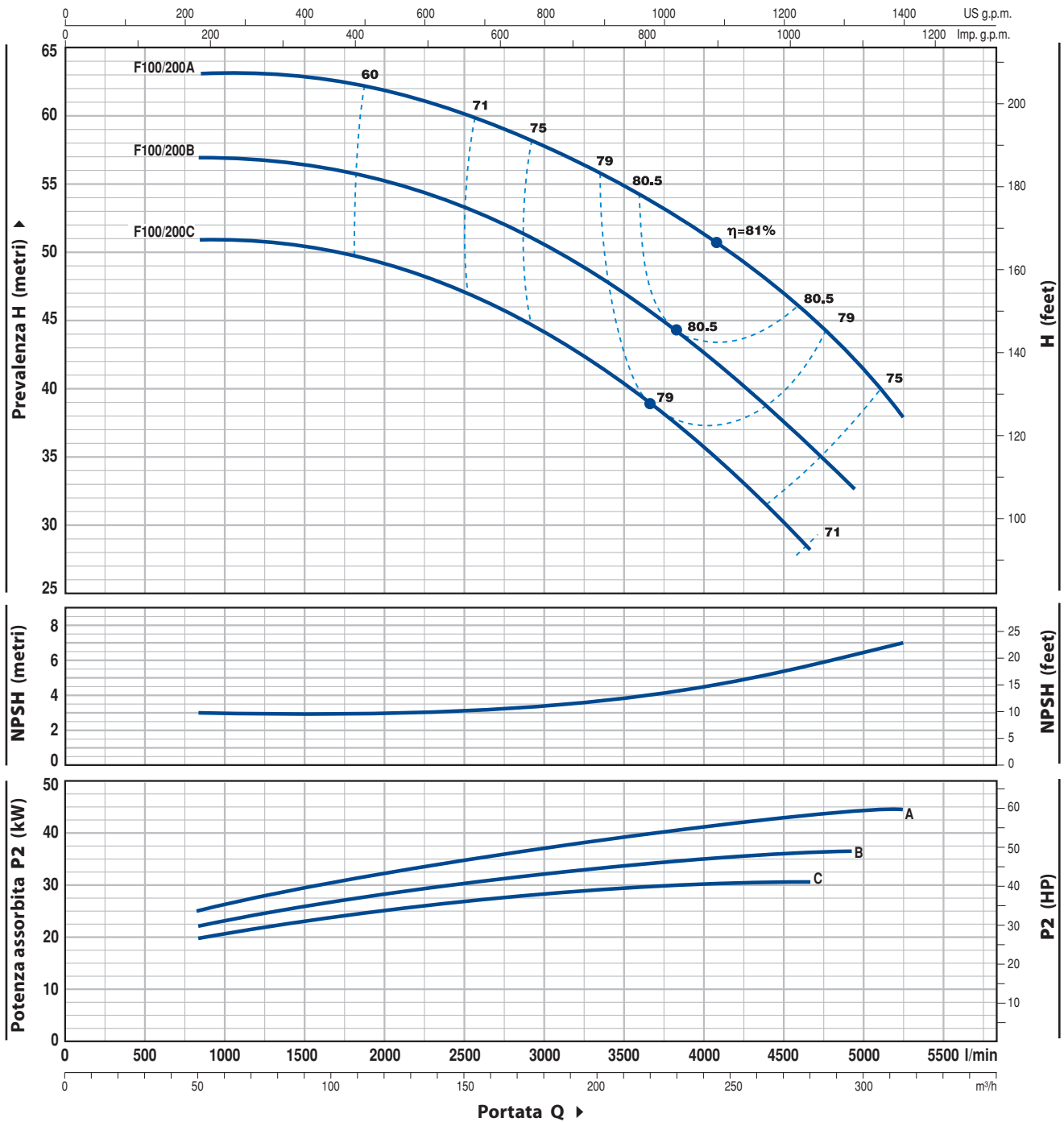

TIPO	POTENZA		Q	0	50	100	150	200	250	279	294	300	315
	kW	HP		0	833	1667	2500	3333	4167	4650	4900	5000	5250
Trifase													
F 100/200C	30	40	H metri	51	51	50	47	41.5	34	28			
F 100/200B	37	50		57	57	56	53	48	41	36	33		
F 100/200A	45	60		63	63	62.5	60	56	50	45	42.5	41.5	38

Q = Portata H = Prevalenza manometrica totale HS = Altezza di aspirazione

Tolleranza delle curve di prestazione secondo EN ISO 9906 App. A.

## CURVE E DATI DI PRESTAZIONE

50 Hz n= 2900 1/min HS= 0 m

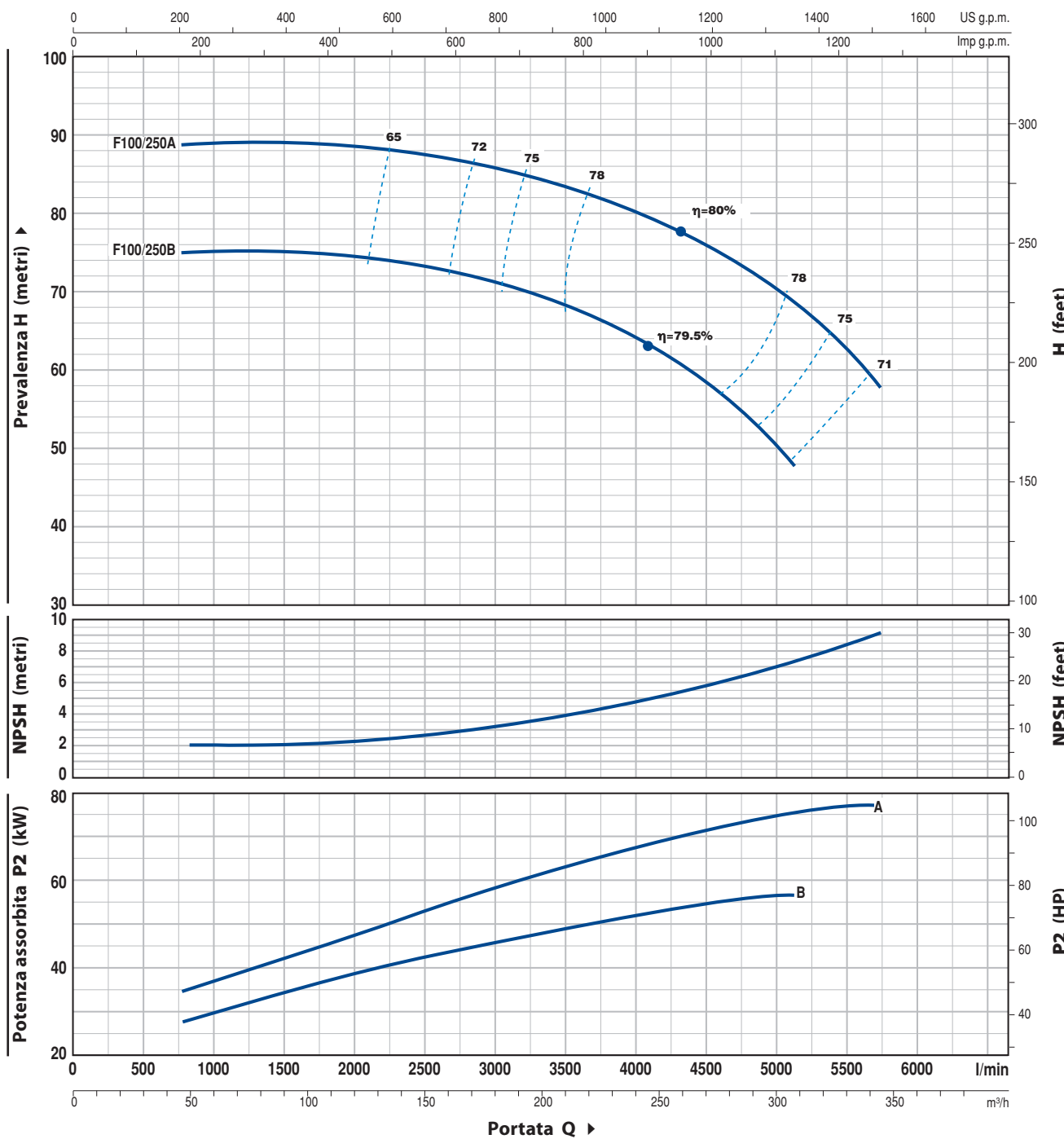

TIPO	POTENZA		Q	48	96	150	180	210	240	300	309	345
	kW	HP		800	1600	2500	3000	3500	4000	5000	5150	5750
Trifase			H metri	75	75	74	71.5	69	64.5	51	48	
<b>F 100/250B</b>	55	75		89	89	88.5	87	84	80.5	70.5	69	58
<b>F 100/250A</b>	75	100										

Q = Portata H = Prevalenza manometrica totale HS = Altezza di aspirazione

Tolleranza delle curve di prestazione secondo EN ISO 9906 App. A.

POS.	COMPONENTE	CARATTERISTICHE COSTRUTTIVE					
1	<b>CORPO POMPA</b>	Ghisa, provvisto di bocche di aspirazione e di mandata flangiate					
2	<b>CONTROFLANGE</b>	Acciaio, provviste di filettatura ISO 228/1					
3a	<b>COPERCHIO</b>	Ghisa					
3b	<b>LANTERNA</b>	Ghisa					
4	<b>GIRANTE</b>	Ottone per F32/160, F32/200, F40/160, F40/200, F50/125, F50/160 Ghisa per F40/250, F50/200, F50/250, F65/125, F65/160, F65/200, F65/250, F80/160, F80/200, F80/250, F100/160, F100/200, F100/250					
5	<b>ALBERO MOTORE</b>	Acciaio inox EN 10088-3 - 1.4104					
6	<b>TENUTA MECCANICA</b>	<b>Elettropompa</b>	<b>Tenuta</b>	<b>Albero</b>	<b>Materiali</b>		
		<b>Tipo</b>	<b>Tipo</b>	<b>Diametro</b>	<i>Anello fisso</i>	<i>Anello rotante</i>	<i>Elastomero</i>
		F32/160 F40/160 F50/125	<b>FN-20</b>	<b>Ø 20 mm</b>	Grafite	Ceramica	NBR
		F32/200 F40/200 F50/160 F65/125	<b>FN-24</b>	<b>Ø 24 mm</b>	Grafite	Ceramica	NBR
		F50/200 F65/160 F65/200 F80/160 F100/160	<b>FN-32 NU</b>	<b>Ø 32 mm</b>	Grafite	Ceramica	NBR
		F40/250 F50/250	<b>FN-38</b>	<b>Ø 38 mm</b>	Grafite	Ceramica	NBR
		F65/250 F80/200 F80/250B F100/200	<b>FN-40</b>	<b>Ø 40 mm</b>	Grafite	Ceramica	NBR
		F80/250A F100/250	<b>FH-45 NU</b>	<b>Ø 45 mm</b>	Grafite	Ceramica	NBR
7	<b>CUSCINETTI</b>	<b>Elettropompa</b>	<b>Tipo</b>	<b>Elettropompa</b>	<b>Tipo</b>		
		F32/160C F32/160B F40/160C F50/125C	<b>6206 ZZ - C3 / 6204 ZZ</b>	F32/200 F40/200 F50/160 F65/125	<b>6307 ZZ - C3 / 6206 ZZ - C3</b>		
		Fm32/160B F32/160A Fm40/160C F40/160B Fm50/125C F50/125B	<b>6206 ZZ - C3 / 6205 ZZ</b>	F40/250 F50/200 F50/250 F65/160 F65/200 F80/160 F100/160	<b>6310 ZZ - C3 / 6308 ZZ - C3</b>		
		F40/160A F50/125A	<b>6306 ZZ - C3 / 6206 ZZ - C3</b>	F65/250 F80/200 F80/250B F100/200	<b>6312 ZZ - C3 / 6212 ZZ - C3</b>		
				F80/250A F100/250	<b>6314 ZZ - C3 / 6314 ZZ - C3</b>		
8	<b>CONDENSATORE</b>	<b>Elettropompa</b>	<b>Capacità</b>				
		<b>Monofase</b>	<b>(230 V o 240 V)</b>				
		Fm32/160B	<b>70 µF 450 VL</b>				
		Fm40/160C	<b>70 µF 450 VL</b>				
		Fm50/125C	<b>70 µF 450 VL</b>				
9	<b>MOTORE ELETTRICO</b>	<b>Fm:</b> monofase 230 V - 50 Hz con salvamotore termico incorporato nell'avvolgimento (fino a 1.5 kW)					
		<b>F:</b> trifase 230/400 V - 50 Hz fino a 4 kW 400/690 V - 50 Hz da 5.5 a 75 kW					
		<p>► <b>Le pompe equipaggiate con motori trifase sono ad alto rendimento in classe IE2 (IEC 60034-30)</b></p> <p>– Isolamento: classe F</p> <p>– Protezione: IP 55</p>					

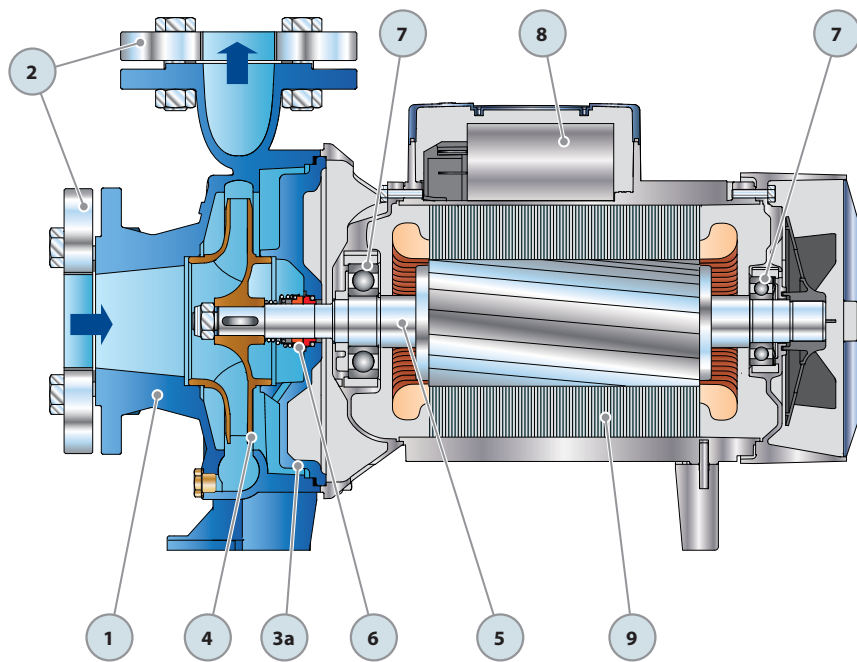

**Versione monofase**

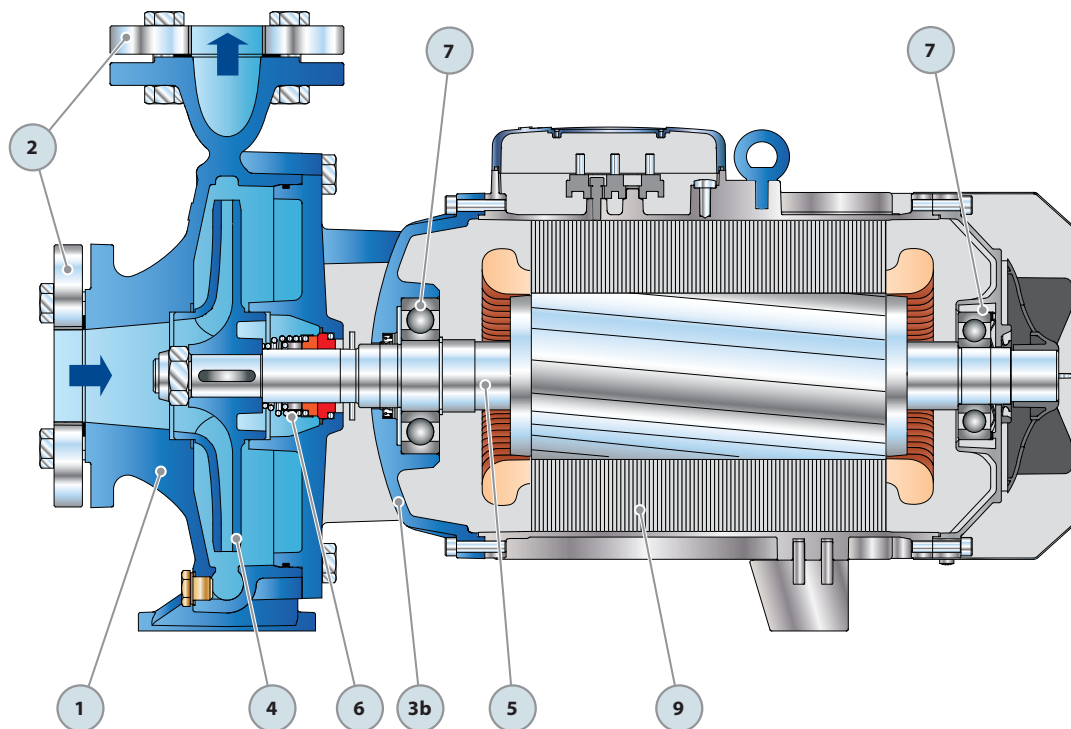

**Versione trifase**



## DIMENSIONI E PESI

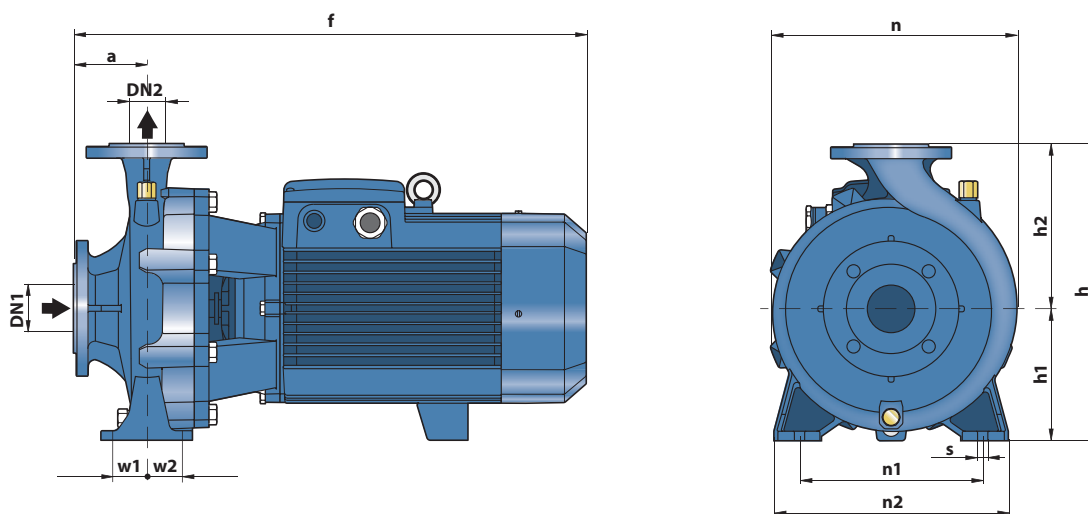

TIPO		BOCCHIE		DIMENSIONI mm											kg *										
Monofase	Trifase	DN1	DN2	a	f	h	h1	h2	n	n1	n2	w1	w2	s	1~	3~									
-	F 32/160C	50	32	80	412	292	132	160	242	190	240	35	35	14	-	37.0									
Fm 32/160B	F 32/160B				42.6										38.5										
-	F 32/160A				-										42.6										
-	F 32/200C				-										52.0										
-	F 32/200B				-										57.0										
-	F 32/200A				-										61.0										
-	F 32/200BH				-										47.9										
-	F 32/200AH				-										51.1										
Fm 40/160C	F 40/160C				-										43.9	40.0									
-	F 40/160B				-										-	44.0									
-	F 40/160A	-	-	50.1																					
-	F 40/200B	65	40	535	340	160	180	275	212	265	47.5	47.5	14	-	61.0										
-	F 40/200A				-									67.0											
-	F 40/250C				-									103.0											
-	F 40/250B				-									109.0											
-	F 40/250A				-									125.0											
Fm 50/125C	F 50/125C				-									44.2	40.1										
-	F 50/125B				-									-	44.1										
-	F 50/125A				-									-	50.7										
-	F 50/160C				-									-	55.0										
-	F 50/160B				-									-	60.6										
-	F 50/160A	-	-	64.7																					
-	F 50/200C	65	50	100	616	160	180	269	212	265	35	35	14	-	106.0										
-	F 50/200B				711									360	200	316	-	128.0							
-	F 50/200A				-									-	-	-	-	135.0							
-	F 50/200AR				-									-	-	-	-	147.0							
-	F 50/250D				-									-	-	-	-	106.0							
-	F 50/250C				-									-	-	-	-	113.4							
-	F 50/250B				-									-	-	-	-	129.6							
-	F 50/250A				-									-	-	-	-	146.0							
-	F 50/250AR				-									-	-	-	-	155.0							
-	F 65/125C				80									65	100	511	340	160	180	291	212	280	47.5	47.5	14
-	F 65/125B	557	-	-		-	-	66.8																	
-	F 65/125A	-	-	-		-	-	74.0																	
-	F 65/160C	621	360	200		300	-	100.0																	
-	F 65/160B	716	-	-		-	-	106.5																	
-	F 65/160A	-	-	-		-	-	123.0																	
-	F 65/200B	719	-	-		-	-	128.0																	
-	F 65/200A	-	-	-		-	-	125.0																	
-	F 65/200AR	751	-	-		-	-	153.1																	
-	F 80/160D	652	405	180		225	250	320	-	111.5															
-	F 80/160C	100	80	125	747	330	-	-	-	-	-	-	-	-	126.0										
-	F 80/160B				779		-	-	-	-	-	-	-	-	-	-	143.5								
-	F 80/160A				-		-	-	-	-	-	-	-	-	-	-	153.0								
-	F 100/160C	125	100	125	758	480	200	280	362	280	360	60	60	18	-	139.0									
-	F 100/160B				790										-	-	-	-	-	-	-	-	-	-	153.7
-	F 100/160A				-										-	-	-	-	-	-	-	-	-	-	165.0

(\* peso con controflange)

## DIMENSIONI E PESI

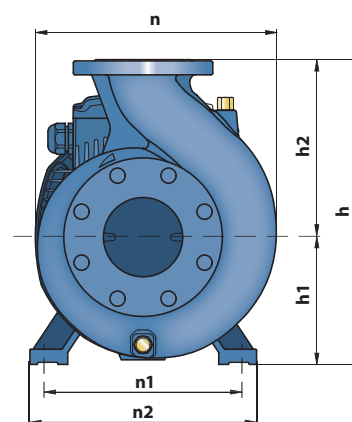
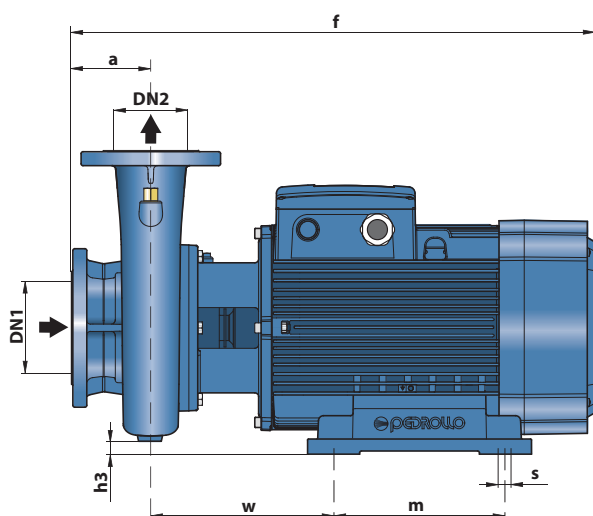

DN FLANGE	D mm	K mm	FORI	
			N°	Ø (mm)
32	140	100	4	18
40	150	110		
50	165	125		
65	185	145		
80	200	160	8	18
100	220	180		
125	250	210		

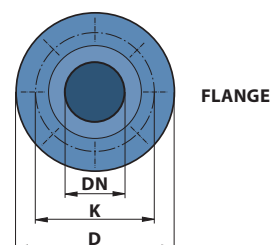

TIPO	BOCCHIE		DIMENSIONI mm											kg *	
	DN1	DN2	a	f	h	h1	h2	h3	n	n1	n2	w	m		s
Trifase															3~
F 65/250C	80	65	100	796	450	200	250	15	369	318	360	269.5	305	18.5	210.0
F 65/250B				847											230.0
F 65/250A				847											230.0
F 80/200B	100	80	125	824	430	280	25	360	318	360	269.5	305	18.5	212.0	
F 80/200A				875										222.5	
F 80/250B				872										245.0	
F 80/250A	125	100	140	1015	620	250	280	55	490	400	490	294	350	24	497.0
F 100/200C				824											208.5
F 100/200B				875											239.0
F 100/200A	125	100	140	875	480	200	280	0	391	318	360	269.5	305	18.5	240.0
F 100/250B				875											498.5
F 100/250A				875											498.5

(\* peso con controflange)

## CONTROFLANGE

DN FLANGE	F CONTROFLANGE	D mm	K mm	FORI	
				N°	Ø (mm)
32	1¼"	140	100	4	18
40	1½"	150	110		
50	2"	165	125		
65	2½"	185	145		
80	3"	200	160	8	18
100	4"	220	180		
125	5"	250	210		

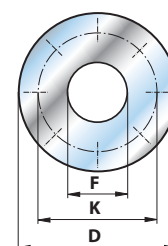

## ASSORBIMENTI

TIPO	TENSIONE (monofase)	
	230 V	240 V
Monofase		
Fm 32/160B	<b>15.0 A</b>	<b>13.8 A</b>
Fm 40/160C	<b>15.0 A</b>	<b>13.8 A</b>
Fm 50/125C	<b>15.0 A</b>	<b>13.8 A</b>

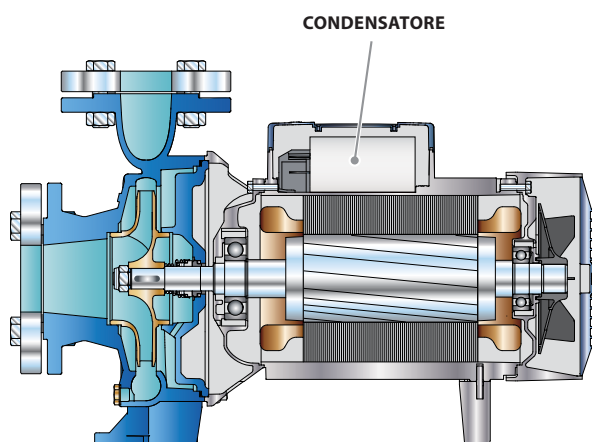

**Versione monofase**

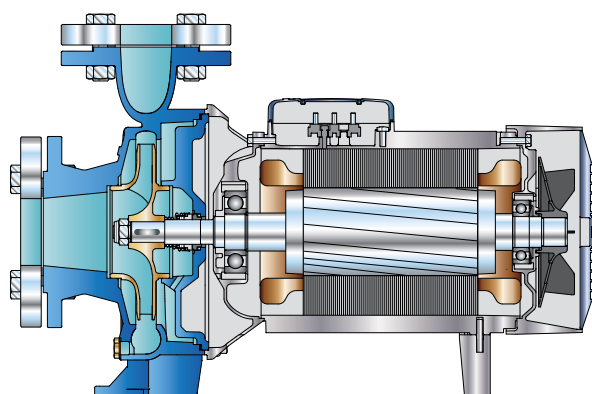

**Versione trifase**

TIPO	TENSIONE (trifase)		
	230÷240 V	400÷415 V	690÷720 V
Trifase			
F 32/160C	<b>7.5 A</b>	<b>4.3 A</b>	<b>2.5 A</b>
F 32/160B	<b>10.0 A</b>	<b>5.8 A</b>	<b>3.4 A</b>
F 32/160A	<b>12.0 A</b>	<b>7.3 A</b>	<b>4.2 A</b>
F 32/200C	<b>17.9 A</b>	<b>10.3 A</b>	<b>5.9 A</b>
F 32/200B	-	<b>11.7 A</b>	<b>6.7 A</b>
F 32/200A	-	<b>14.9 A</b>	<b>8.6 A</b>
F 32/200BH	<b>12.6 A</b>	<b>7.3 A</b>	<b>4.2 A</b>
F 32/200AH	<b>15.4 A</b>	<b>8.9 A</b>	<b>5.1 A</b>
F 40/160C	<b>9.9 A</b>	<b>5.7 A</b>	<b>3.3 A</b>
F 40/160B	<b>12.0 A</b>	<b>6.9 A</b>	<b>4.0 A</b>
F 40/160A	<b>17.2 A</b>	<b>9.9 A</b>	<b>5.7 A</b>
F 40/200B	-	<b>12.6 A</b>	<b>7.3 A</b>
F 40/200A	-	<b>15.6 A</b>	<b>9.0 A</b>
F 40/250C	-	<b>21.0 A</b>	<b>12.1 A</b>
F 40/250B	-	<b>23.5 A</b>	<b>13.6 A</b>
F 40/250A	-	<b>30.5 A</b>	<b>17.6 A</b>
F 50/125C	<b>9.4 A</b>	<b>5.4 A</b>	<b>3.1 A</b>
F 50/125B	<b>12.0 A</b>	<b>6.9 A</b>	<b>4.0 A</b>
F 50/125A	<b>16.3 A</b>	<b>9.4 A</b>	<b>5.4 A</b>
F 50/160C	<b>15.8 A</b>	<b>9.1 A</b>	<b>5.3 A</b>
F 50/160B	-	<b>12.3 A</b>	<b>7.1 A</b>
F 50/160A	-	<b>15.5 A</b>	<b>8.9 A</b>
F 50/200C	-	<b>23 A</b>	<b>13.3 A</b>
F 50/200B	-	<b>29.5 A</b>	<b>17 A</b>
F 50/200A	-	<b>34.5 A</b>	<b>20 A</b>
F 50/200AR	-	<b>41.5 A</b>	<b>24 A</b>
F 50/250D	-	<b>17.2 A</b>	<b>9.9 A</b>
F 50/250C	-	<b>21.0 A</b>	<b>12.0 A</b>
F 50/250B	-	<b>27.0 A</b>	<b>15.6 A</b>
F 50/250A	-	<b>34.0 A</b>	<b>19.6 A</b>
F 50/250AR	-	<b>41.0 A</b>	<b>24.0 A</b>
F 65/125C	<b>17.5 A</b>	<b>10.0 A</b>	<b>5.8 A</b>
F 65/125B	-	<b>12.0 A</b>	<b>7.0 A</b>
F 65/125A	-	<b>16.5 A</b>	<b>9.5 A</b>
F 65/160C	-	<b>19.0 A</b>	<b>11.0 A</b>
F 65/160B	-	<b>23.0 A</b>	<b>13.5 A</b>
F 65/160A	-	<b>27.5 A</b>	<b>16.0 A</b>
F 65/200B	-	<b>30.0 A</b>	<b>17.3 A</b>
F 65/200A	-	<b>35.0 A</b>	<b>20.2 A</b>
F 65/200AR	-	<b>41.0 A</b>	<b>24.0 A</b>
F 65/250C	-	<b>53.0 A</b>	<b>31.0 A</b>
F 65/250B	-	<b>65.0 A</b>	<b>38.0 A</b>
F 65/250A	-	<b>79.0 A</b>	<b>46.0 A</b>
F 80/160D	-	<b>22.0 A</b>	<b>13.0 A</b>
F 80/160C	-	<b>29.0 A</b>	<b>17.0 A</b>
F 80/160B	-	<b>34.5 A</b>	<b>20.0 A</b>
F 80/160A	-	<b>39.0 A</b>	<b>22.5 A</b>
F 80/200B	-	<b>53.0 A</b>	<b>31.0 A</b>
F 80/200A	-	<b>65.0 A</b>	<b>38.0 A</b>
F 80/250B	-	<b>79.0 A</b>	<b>46.0 A</b>
F 80/250A	-	<b>98.0 A</b>	<b>57.0 A</b>
F 100/160C	-	<b>31.0 A</b>	<b>18.0 A</b>
F 100/160B	-	<b>36.0 A</b>	<b>21.0 A</b>
F 100/160A	-	<b>42.0 A</b>	<b>24.0 A</b>
F 100/200C	-	<b>53.0 A</b>	<b>31.0 A</b>
F 100/200B	-	<b>65.0 A</b>	<b>38.0 A</b>
F 100/200A	-	<b>79.0 A</b>	<b>46.0 A</b>
F 100/250B	-	<b>98.0 A</b>	<b>57.0 A</b>
F 100/250A	-	<b>126.0A</b>	<b>73.0 A</b>

## PALLETIZZAZIONE

TIPO		PER GROUPAGE			
Monofase	Trifase	n° pompe	H (mm)	kg	
				1~	3~
-	F 32/160C	18	1430	-	683
Fm 32/160B	F 32/160B	18	1430	781	707
-	F 32/160A	18	1430	-	784
-	F 32/200C	12	1535	-	641
-	F 32/200B	12	1535	-	701
-	F 32/200A	12	1535	-	749
-	F 32/200BH	12	1535	-	591
-	F 32/200AH	12	1535	-	629
Fm 40/160C	-	12	1400	509	-
-	F 40/160C	18	1430	-	735
-	F 40/160B	18	1430	-	809
-	F 40/160A	12	1400	-	617
-	F 40/200B	12	1535	-	749
-	F 40/200A	12	1535	-	821
-	F 40/250C	6	1200	-	635
-	F 40/250B	6	1200	-	671
-	F 40/250A	6	1200	-	767
Fm 50/125C	-	18	1430	820	-
-	F 50/125C	12	1400	-	498
-	F 50/125B	18	1430	-	810
-	F 50/125A	12	1535	-	625
-	F 50/160C	12	1535	-	677
-	F 50/160B	12	1535	-	744
-	F 50/160A	12	1535	-	793
-	F 50/200C	6	1200	-	653
-	F 50/200B	6	1200	-	785
-	F 50/200A	6	1200	-	827
-	F 50/200AR	6	1380	-	899
-	F 50/250D	6	1200	-	653
-	F 50/250C	6	1200	-	697
-	F 50/250B	6	1200	-	794
-	F 50/250A	6	1200	-	893
-	F 50/250AR	6	1380	-	947
-	F 65/125C	12	1535	-	769
-	F 65/125B	12	1535	-	818
-	F 65/125A	12	1535	-	905
-	F 65/160C	6	1200	-	617
-	F 65/160B	6	1200	-	656
-	F 65/160A	6	1200	-	755
-	F 65/200B	6	1200	-	785
-	F 65/200A	6	1200	-	767
-	F 65/200AR	6	1380	-	936
-	F 65/250C	1	450	-	227
-	F 65/250B	1	450	-	247
-	F 65/250A	1	450	-	247
-	F 80/160D	6	1200	-	686
-	F 80/160C	6	1380	-	773
-	F 80/160B	6	1380	-	878
-	F 80/160A	6	1380	-	935
-	F 80/200B	1	450	-	229
-	F 80/200A	1	450	-	240
-	F 80/250B	1	450	-	262
-	F 80/250A	1	770	-	514
-	F 100/160C	6	1380	-	851
-	F 100/160B	6	1380	-	939
-	F 100/160A	6	1380	-	1007
-	F 100/200C	1	450	-	226
-	F 100/200B	1	450	-	256
-	F 100/200A	1	450	-	257
-	F 100/250B	1	770	-	516
-	F 100/250A	1	770	-	516

