

## Catena a rulli doppia serie UNI

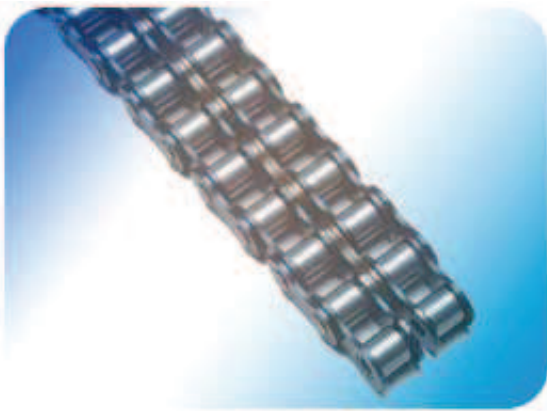

**FKK**<sup>®</sup>  
- ISO 9001 -

Serie  
UNI 2578  
DIN 81808187

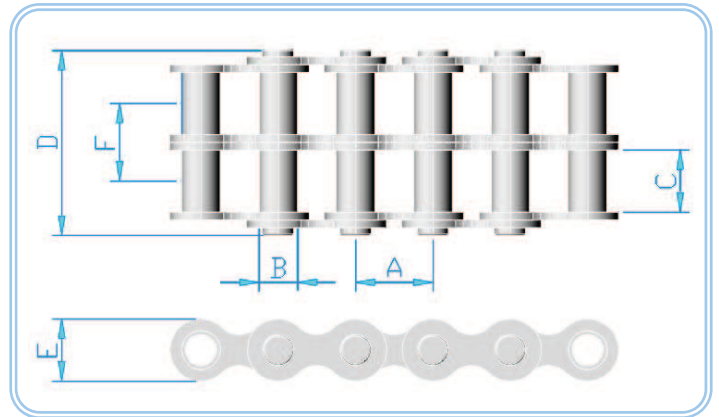

Fornibili giunzioni per catene e false maglie

### CATENA A RULLI DOPPIA SERIE UNI

Rif.	UNI		A	B	C	D	E	F	Carico Rottura		Peso
	Pollici	m/m							KG	N	
<b>05B-2</b>	8X3	8.00X3.00	8,00	5,00	3,00	20,20	7,11	5,64	800	7.848	0,31
<b>06B-2</b>	3/8X7/32	9.525X5.72	9,525	6,35	5,72	22,80	8,30	10,24	2000	19.620	0,78
<b>08B-2</b>	1/2X5/16	12.70X7.75	12,70	8,51	7,75	30,40	11,80	13,92	3800	37.278	1,35
<b>10B-2</b>	5/8X3/8	15.875X9.65	15,875	10,16	9,65	35,70	14,00	16,59	5000	49.050	1,85
<b>12B-2</b>	3/4X7/16	19.05X11.68	19,05	12,07	11,68	41,60	18,00	19,46	6000	58.860	2,50
<b>16B-2</b>	1X17,02	25.4X17.02	25,40	15,88	17,00	67,90	21,00	31,88	12400	121.644	5,40
<b>20B-2</b>	1"1/4X3/4	31.75X19.56	31,75	19,05	19,60	77,80	25,50	36,45	19000	186.390	7,20
<b>24B-2</b>	1"1/2X1"	38.10X25.40	38,10	25,40	25,40	102,50	33,70	48,36	32400	317.844	13,50
<b>28B-2</b>	1"3/4X1"1/4	44.45X31,00	44,45	27,94	31,00	125,50	34,50	59,56	38100	373.761	16,60
<b>32B-2</b>	2"X1"1/4	50.80X31,00	50,80	29,21	31,00	124,20	40,50	58,55	49500	485.595	21,00
<b>40B-2</b>	2"1/2X1"1/2	63.5X38,10	63,50	39,37	38,10	154,90	52,96	72,29	78000	765.180	32,00
<b>48B-2</b>	3"X45,7	76.2X45,72	76,20	48,26	45,72	190,40	63,88	91,21	20000	196.200	50,00