

MADE IN ITALY

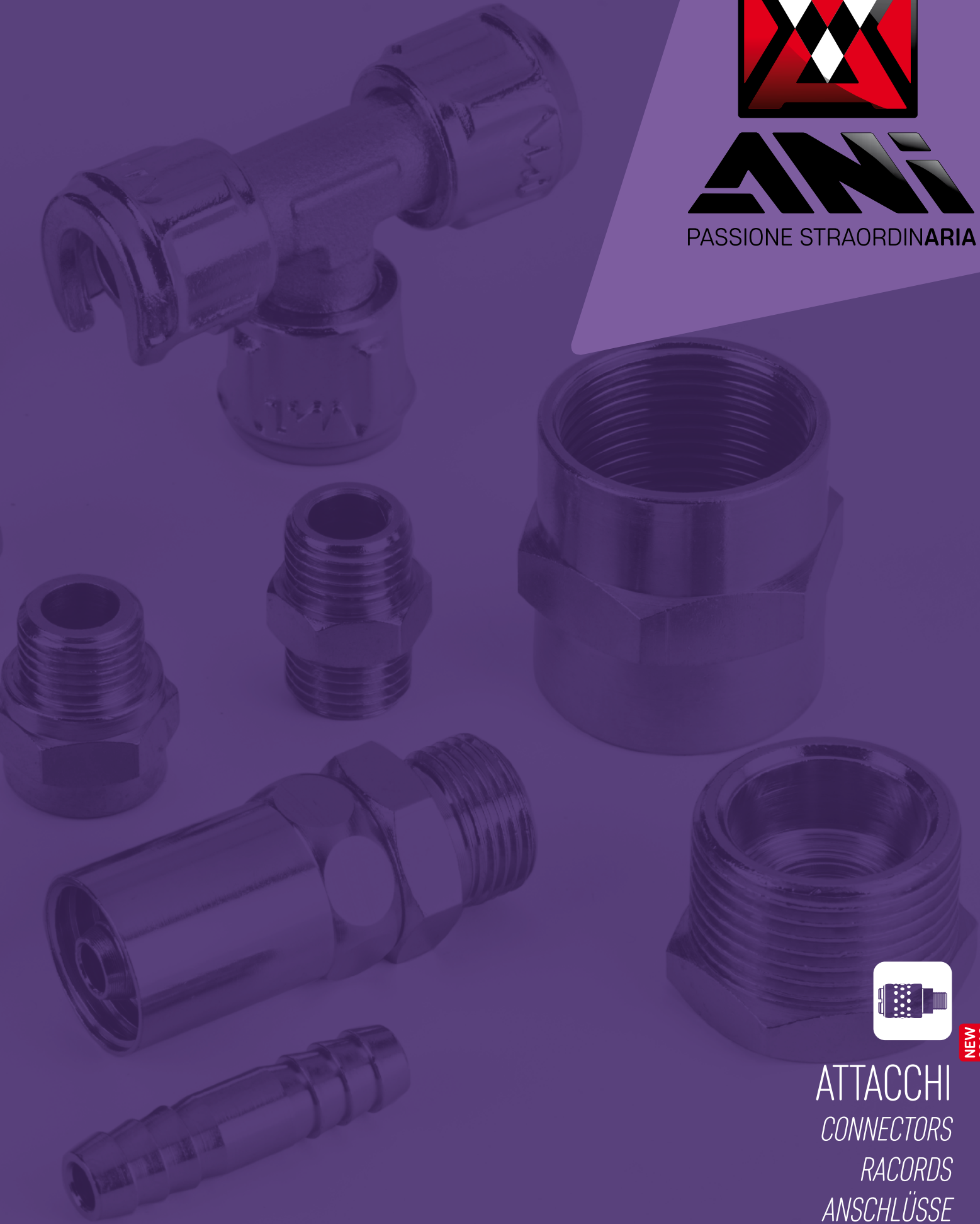

ANI
PASSIONE STRAORDINARIA



NEW
2019

ATTACCHI
CONNECTORS
RACORDS
ANSCHLÜSSE



10/A | 10/B

ATTACCO A BAIONETTA CON MASCHERINA PORTAGOMMA
 BAYONET CONNECTOR WITH SLEEVE FOR RUBBER HOSE
 RACCORD A BAIONNETTE MALE AVEC MANCHON PORTE-TUYAU
 BAJONNETT-ANSCHLUSS MIT GUMMISCHLAUCHHALTEVERKLEIDUNG

- Ottone Nichelato (UNI EN 12164 CW 614N)
- Guarnizione in gomma NBR
- Laiton nickelé (UNI EN 12164 CW 614N)
- Joint en caoutchouc NBR
- Nickel-plated brass (UNI EN 12164 CW 614N)
- NBR rubber washers
- Vernickeltes Messing (UNI EN 12164 CW 614N)
- NBR-Dichtungen

COD.	MOD.	Di X De	f	P	L				
AH010102	10/A	ø 6 x 13	ø 4	30	47	14	17	10	46
AH010103	10/A	ø 6 x 14	ø 4	30	47	14	17	10	45
AH010104	10/A	ø 6 x 15	ø 4	30	47	14	19	10	45
AH010105	10/A	ø 6 x 16	ø 4	30	47	14	19	10	50
AH010106	10/B	ø 7 x 16	ø 4.5	30	47	14	19	10	51
AH010110	10/B	ø 8 x 12	ø 4.5	30	47	14	17	10	49
AH010113	10/B	ø 8 x 15	ø 4.5	30	47	14	19	10	49
AH010107	10/B	ø 8 x 17	ø 4.5	30	47	14	19	10	53
AH010108	10/B	ø 10 x 17	ø 4.5	30	47	14	20	10	59
AH010109	10/B	ø 10 x 19	ø 4.5	30	47	14	22	10	70
BB0180551	Guarnizione Washer 10/A-10/B								50

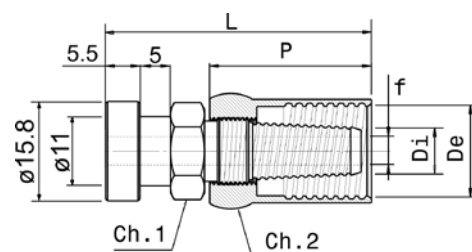

Guarnizione - Washer - Joint - Dichtung

10/H

ATTACCO PORTAGOMMA A RESCA
 RUBBER HOSE CONNECTOR WITH TAILPIECE
 RACCORD PORTE-TUYAU A EPI
 GUMMISCHLAUCHHALTERANSCHLUSS MIT SCHLAUCHTÜLLE

- Ottone Nichelato (UNI EN 12164 CW 614N)
- Laiton nickelé (UNI EN 12164 CW 614N)
- Nickel-plated brass (UNI EN 12164 CW 614N)
- Vernickeltes Messing (UNI EN 12164 CW 614N)

COD.	MOD.	D	f	P	L		
AS011701	10/H	ø 6	ø 3.5	14.5	35	10	5
AS011702	10/H	ø 8	ø 4.5	14.5	35	10	9
AS011703	10/H	ø 10	ø 6	18.5	43	10	16

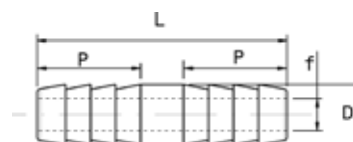



10/C

ATTACCO FILETTATO MASCHIO CON MASCHERINA PORTAGOMMA | MALE THREADED CONNECTOR WITH SLEEVE FOR RUBBER HOSE
RACCORD FILETE MÂLE AVEC MANCHON PORTE-TUYAU | ANSCHLUSS MIT AUSSENGEWINDE UND GUMMISCHLAUCHHALTEVERKLEIDUNG

- Maschio cilindrico ISO 228 (BSPP)
- Ottone Nichelato (UNI EN 12164 CW 614N)
- Mâle cylindrique ISO 228 (BSPP)
- Laiton nickelé (UNI EN 12164 CW 614N)
- Cylindrical male thread - ISO 228 (BSPP)
- Nickel-plated brass (UNI EN 12164 CW 614N)
- Zylindrisches Außengewinde ISO 228 (BSPP)
- Vernickeltes Messing (UNI EN 12164 CW 614N)

COD.	MOD.	F	Di X De	f	P1	P2	L				
AH010212	10/C	1/4M	ø 6x14	ø 4	10.5	30	47	16	17	10	44
AH010232	10/C	1/4M	ø 8x12	ø 5	10.5	30	47	16	17	10	46
AH010230	10/C	1/4M	ø 8x14	ø 5	10.5	30	47	16	17	10	47
AH010216	10/C	1/4M	ø 8x17	ø 5	10.5	30	47	16	19	10	51
AH010221	10/C	3/8M	ø 6x14	ø 4	10.5	30	47	19	17	10	49
AH010233	10/C	3/8M	ø 8x12	ø 5	10.5	30	47	19	17	10	53
AH010225	10/C	3/8M	ø 8x17	ø 5	10.5	30	47	19	19	10	59

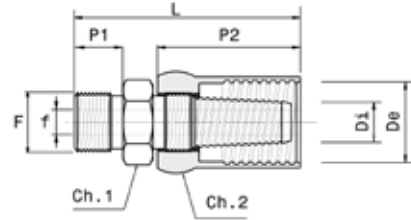

10/D

ATTACCO FILETTATO FEMMINA CON MASCHERINA PORTAGOMMA | FEMALE THREADED CONNECTOR WITH SLEEVE FOR RUBBER HOSE
RACCORD FILETE FEMELLE AVEC MANCHON PORTE-TUYAU | ANSCHLUSS MIT INNENGEWINDE UND SCHLAUCHTÜLLE

- Femmina cilindrico ISO 228 (BSPP)
- Ottone Nichelato (UNI EN 12164 CW 614N)
- Femelle cylindrique ISO 228 (BSPP)
- Laiton nickelé (UNI EN 12164 CW 614N)
- Cylindrical female thread - ISO 228 (BSPP)
- Nickel-plated brass (UNI EN 12164 CW 614N)
- Zylindrisches Innengewinde ISO 228 (BSPP)
- Vernickeltes Messing (UNI EN 12164 CW 614N)

COD.	MOD.	F	Di X De	f	P1	P2	L				
AH010312	10/D	1/4F	ø 6x14	ø 4	12	30	46	16	17	10	44
AH010315	10/D	1/4F	ø 8x12	ø 5	12	30	46	16	17	10	47
AH010316	10/D	1/4F	ø 8x17	ø 5	12	30	46	16	19	10	51
AH010321	10/D	3/8F	ø 6x14	ø 4	12	30	46	19	17	10	46
AH010325	10/D	3/8F	ø 8x12	ø 5	12	30	46	19	17	10	49
AH010331	10/D	3/8F	ø 8x17	ø 5	12	30	46	19	19	10	54

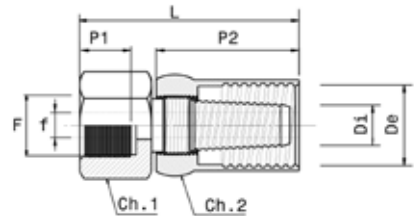

10/F

ATTACCO A BAIONETTA CON RESCA | BAYONET CONNECTOR WITH TAILPIECE | RACCORD A BAIONNETTE AVEC PORTE-TUYAU A EPI | BAJONETT-ANSCHLUSS MIT SCHLAUCHTÜLLE

- Ottone Nichelato (UNI EN 12164 CW 614N)
- Guarnizione in gomma NBR
- Laiton nickelé (UNI EN 12164 CW 614N)
- Joint en caoutchouc NBR
- Nickel-plated brass (UNI EN 12164 CW 614N)
- NBR rubber washers
- Vernickeltes Messing (UNI EN 12164 CW 614N)
- NBR-Dichtungen

COD.	MOD.	D	P	L	f		
AH010501	10/F	ø 6	18.5	33.5	3	10	19
AH010502	10/F	ø 7	18.5	33.5	3.75	10	17
AH010503	10/F	ø 8	18.5	33.5	4.5	10	20
AH010506	10/F	ø 9	20.5	35.5	4.5	10	22
AH010504	10/F	ø 10	23.5	38.5	4.5	10	26
BB0180551	Guarnizione Washer 10/A-10/B					50	

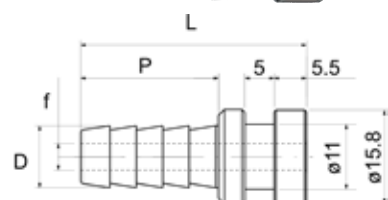



10/E

ATTACCO PORTAGOMMA A RESCA FILETTATO MASCHIO | MALE THREADED RUBBER HOSE CONNECTOR WITH TAILPIECE
RACCORD PORTE-TUYAU A EPI FILETE MALE | ANSCHLUSS MIT AUSSENGEWINDE UND SCHLAUCHTÜLLE

- Maschio cilindrico ISO 228 (BSPP)
- Ottone Nichelato (UNI EN 12164 CW 614N)
- Mâle cylindrique ISO 228 (BSPP)
- Laiton nickelé (UNI EN 12164 CW 614N)
- Cylindrical male thread - ISO 228 (BSPP)
- Nickel-plated brass (UNI EN 12164 CW 614N)
- Zylindrisches Außengewinde ISO 228 (BSPP).
- Vernickeltes Messing (UNI EN 12164 CW 614N)

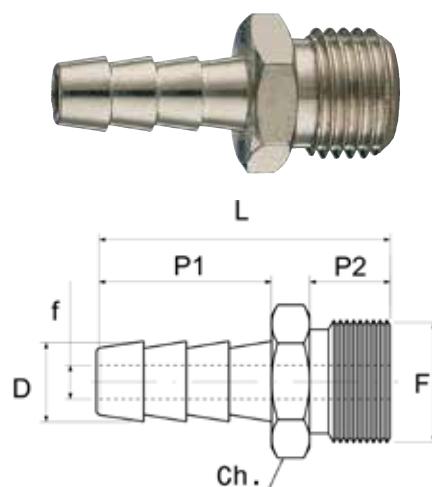

COD.	MOD.	F	D	f	P1	P2	L			
AS010401	10/E	1/8M	ø 6	ø3	18.5	7.5	30	11	10	12
AS010402	10/E	1/8M	ø 7	ø4	18.5	7.5	30	11	10	9
AS010403	10/E	1/8M	ø 8	ø5	18.5	7.5	30	11	10	10
AS010404	10/E	1/4M	ø 6	ø3	18.5	8.5	31	14	10	12
AS010405	10/E	1/4M	ø 7	ø4	18.5	8.5	31	14	10	16
AS010406	10/E	1/4M	ø 8	ø5	18.5	8.5	31	14	10	10
AS010407	10/E	1/4M	ø 9	ø5.5	20.5	8.5	33	14	10	18
AS010408	10/E	1/4M	ø 10	ø6.5	20.5	8.5	33	14	10	17
AS010409	10/E	1/4M	ø 12	ø7.5	20.5	8.5	33	14	10	10
AS010410	10/E	3/8M	ø 9	ø5.5	23.5	12.5	41	18	10	33
AS010411	10/E	3/8M	ø 10	ø5.5	23.5	12.5	41	18	10	34
AS010412	10/E	3/8M	ø 12	ø7	23.5	12.5	41	18	10	30
AS010460	10/E	3/8M	ø 14	ø9	26.5	12.5	44	18	10	39
AS010413	10/E	1/2M	ø 12	ø7	26.5	12.5	45.5	22	10	46
AS010414	10/E	1/2M	ø 14	ø9	26.5	13.5	46	22	10	45
AS010415	10/E	1/2M	ø 16	ø11	26.5	13.5	46	22	10	50

10/M

MASCHERINA PER ATTACCHI PORTAGOMMA | SLEEVE FOR RUBBER HOSE CONNECTORS
MANCHON POUR RACCORDS PORTE-TUYAU | VERKLEIDUNG FÜR GUMMISCHLAUCHHALTERANSCHLÜSSE

- Femmina cilindrico ISO 228 (BSPP)
- Ottone Nichelato (UNI EN 12164 CW 614N)
- Femelle cylindrique ISO 228 (BSPP)
- Laiton nickelé (UNI EN 12164 CW 614N)
- Cylindrical female thread - ISO 228 (BSPP)
- Nickel-plated brass (UNI EN 12164 CW 614N)
- Zylindrisches Innengewinde ISO 228 (BSPP).
- Vernickeltes Messing (UNI EN 12164 CW 614N)

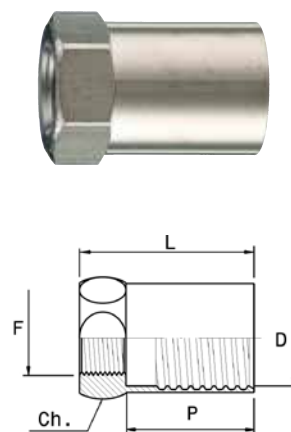

COD.	MOD.	F	P	L	F			
AS010602	10/M	1/4 F	ø 12	19	29	17	10	17
AS010603	10/M	1/4 F	ø 13	22	30	17	10	20
AS010604	10/M	1/4 F	ø 14	22	30	17	10	17
AS010605	10/M	1/4 F	ø 15	22	30	19	10	28
AS010606	10/M	1/4 F	ø 16	22	30	19	10	22
AS010607	10/M	1/4 F	ø 17	22	31	20	10	28
AS010609	10/M	1/4 F	ø 19	23	32	22	10	39
AS010611	10/M	1/2 F	ø 19	28	40	24	10	43
AS010612	10/M	1/2 F	ø 20	28	40	24	10	41
AS010613	10/M	1/2 F	ø 21	28	41	25	10	47
AS010614	10/M	1/2 F	ø 22	28	42	26	10	52
AS010615	10/M	1/2 F	ø 23	28	42	27	10	59



36/E

TESTINA A BAIONETTA FILETTATA MASCHIO | MALE THREADED BAYONET CHUCK
TETE A BAIONNETTE FILETÉE MÂLE | BAJONETTKOPFTEIL MIT AUSSENGEWINDE

- Gas cilindrica ISO 228 (BSPP)
- Ottone Nichelato (UNI EN 12164 CW 614N)
- Guarnizione in gomma NBR
- *Gaz cylindrique ISO 228 (BSPP)*
- *Laiton nickelé (UNI EN 12164 CW 614N)*
- *Joint en caoutchouc NBR*
- *Cylindrical Gas Thread - ISO 228 (BSPP)*
- *Nickel-plated brass (UNI EN 12164 CW 614N)*
- *NBR rubber washers*
- *Zylindrisches Gasgewinde - ISO 228 (BSPP).*
- *Vernickeltes Messing (UNI EN 12164 CW 614N)*
- *NBR-Dichtungen*

COD.	MOD.	F	P	L	f			
AH042201	36/E	1/4M	10.5	27	ø 4.5	16	5	26
AH042202	36/E	3/8M	10.5	27	ø 4.5	17	5	34
BB0180551	Guarnizione Washer x 1/4						50	
BB018056	Guarnizione Washer x 3/8						50	

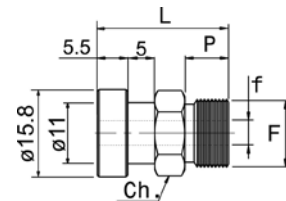

36/F

TESTINA A BAIONETTA FILETTATA FEMMINA | FEMALE THREADED BAYONET CHUCK
TETE A BAIONNETTE FILETÉE FEMELLE | BAJONETTKOPFTEIL MIT INNEGEWINDE

- Gas cilindrica ISO 228 (BSPP)
- Ottone Nichelato (UNI EN 12164 CW 614N)
- Guarnizione in gomma NBR
- *Gaz cylindrique ISO 228 (BSPP)*
- *Laiton nickelé (UNI EN 12164 CW 614N)*
- *Joint en caoutchouc NBR*
- *Cylindrical Gas Thread - ISO 228 (BSPP)*
- *Nickel-plated brass (UNI EN 12164 CW 614N)*
- *NBR rubber washers*
- *Zylindrisches Gasgewinde - ISO 228 (BSPP).*
- *Vernickeltes Messing (UNI EN 12164 CW 614N)*
- *NBR-Dichtungen*

COD.	MOD.	F	P	L	f			
AH042203	36/F	1/4F	11	24	ø 4.5	16	5	21
AH042204	36/F	3/8F	12	26	ø 4.5	19	5	27
BB0180551	Guarnizione Washer x 1/4						50	
BB018056	Guarnizione Washer x 3/8						50	

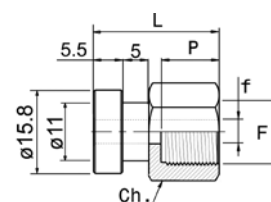



11/A | 11/B

RACCORDO MASCHIO CON DADO FRESATO | MALE FITTING WITH MILLED NUT
RACCORD MALE AVEC ECROU MOLETTE | ANSCHLUSS MIT AUSSENGEWINDE UND GEFRÄSTER MUTTER

- Gas cilindrica - ISO 228 (BSPP)
- Corpo: Ottone Nichelato (CW 614N)
- Dado : ZAMA-5 Nichelata (UNI EN 1774:99)
- Gaz cylindrique - ISO 228 (BSPP)
- Corps : Laiton nickelé (CW 614N)
- Écrou : ZAMAC-5 Nickelée (UNI EN 1774:99)
- Cylindrical gas thread - ISO 228 (BSPP)
- Body: Nickel-plated brass (CW 614N)
- Nut: Nickel-plated ZAMAK-5 (UNI EN 1774:99)
- Zylindrisches Gasgewinde - ISO 228 (BSPP)
- Körper: Vernickeltes Messing (CW 614N)
- Mutter: Vernickelte ZAMA-5 (UNI EN 1774:99)

COD.	MOD.	F	P	L			
AH010901	11/A	1/4M	10	28.5	15	10	33
AH010902	11/B	3/8M	10.5	29	17	10	40

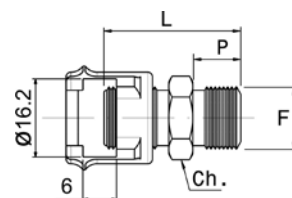

11/C | 11/D

RACCORDO FEMMINA CON DADO FRESATO | FEMALE FITTING WITH MILLED NUT
RACCORD FEMELLE AVEC ECROU MOLETTE | ANSCHLUSS MIT AUSSENGEWINDE UND GEFRÄSTER MUTTER

- Gas cilindrica - ISO 228 (BSPP)
- Corpo: Ottone Nichelato (CW 614N)
- Dado: ZAMA-5 Nichelata (UNI EN 1774:99)
- Gaz cylindrique - ISO 228 (BSPP)
- Corps : Laiton nickelé (CW 614N)
- Écrou : ZAMAC-5 Nickelée (UNI EN 1774:99)
- Cylindrical gas thread - ISO 228 (BSPP)
- Body: Nickel-plated brass (CW 614N)
- Nut: Nickel-plated ZAMAK-5 (UNI EN 1774:99)
- Zylindrisches Gasgewinde - ISO 228 (BSPP)
- Körper: Vernickeltes Messing (CW 614N)
- Mutter: Vernickelte ZAMA-5 (UNI EN 1774:99)

COD.	MOD.	F	P	L			
AH011001	11/C	1/4F	11	27	16	10	34
AH011002	11/D	3/8F	11	27.5	19	10	36

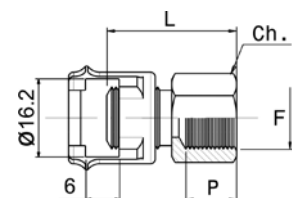

12/A

RACCORDO DI GIUNZIONE CON DUE DADI FRESATI | DOUBLE CONNECTOR WITH TWO MILLED NUTS
RACCORD DE JONCTION AVEC DEUX ECROUS MOLETES | VERBINDUNGSANSCHLUSS MIT ZWEI GEFRÄSTEN MUTTERN

- Gas cilindrica - ISO 228 (BSPP)
- Corpo: Ottone Nichelato (CW 614N)
- Dado : ZAMA-5 Nichelata (UNI EN 1774:99)
- Gaz cylindrique - ISO 228 (BSPP)
- Corps : Laiton nickelé (CW 614N)
- Écrou : ZAMAC-5 Nickelée (UNI EN 1774:99)
- Cylindrical gas thread - ISO 228 (BSPP)
- Body: Nickel-plated brass (CW 614N)
- Nut: Nickel-plated ZAMAK-5 (UNI EN 1774:99)
- Zylindrisches Gasgewinde - ISO 228 (BSPP)
- Körper: Vernickeltes Messing (CW 614N)
- Mutter: Vernickelte ZAMA-5 (UNI EN 1774:99)

COD.	MOD.	F	P	L			
AH011101	12/A	1/4M	13.5	32	15	10	48

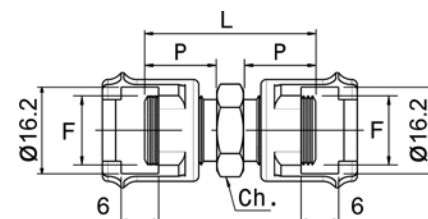



12/B

RACCORDO DI GIUNZIONE CON TRE DADI FRESATI | DOUBLE CONNECTOR WITH THREE MILLED NUTS
RACCORD DE JONCTION AVEC TROIS ECROUS MOLETES | VERBINDUNGSANSCHLUSS MIT DREI GEFRÄSTEN MUTTERN

- Gas cilindrica - ISO 228 (BSPP)
- Corpo: Ottone Nichelato (CW 614N)
- Dado : ZAMA-5 Nichelata (UNI EN 1774:99)
- Gaz cylindrique - ISO 228 (BSPP)
- Corps : Laiton nickelé (CW 614N)
- Écrou : ZAMAC-5 Nickelée (UNI EN 1774:99)
- Cylindrical gas thread - ISO 228 (BSPP)
- Body: Nickel-plated brass (CW 614N)
- Nut: Nickel-plated ZAMAK-5 (UNI EN 1774:99)
- Zylindrisches Gasgewinde - ISO 228 (BSPP)
- Körper: Vernickeltes Messing (CW 614N)
- Mutter: Vernickelte ZAMA-5 (UNI EN 1774:99)

COD.	MOD.	F	H	L			
AH011201	12/B	1/4	25.3	50.6	13	10	90

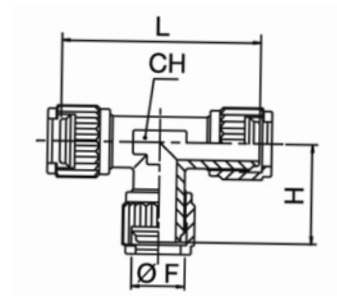

13/A | 13/B

DADO FRESATO | MILLED NUT | ECROU MOLETE | GEFRÄSTE MUTTER

- Gas cilindrica - ISO 228 (BSPP)
- ZAMA-5 Nichelata (UNI EN 1774:99)
- Gaz cylindrique - ISO 228 (BSPP)
- ZAMAC-5 Nickelée (UNI EN 1774:99)
- Cylindrical gas thread - ISO 228 (BSPP)
- Nickel-plated ZAMAK-5 (UNI EN 1774:99)
- Zylindrisches Gasgewinde - ISO 228 (BSPP)
- Vernickelte ZAMA-5 (UNI EN 1774:99)

COD.	MOD.	F	D	L	D1	L1		
A1011303	13/A	1/4M	21.5	18	16.2	6	10	10
A1011302	13/B	3/8M	21.5	18	16.2	6	10	8

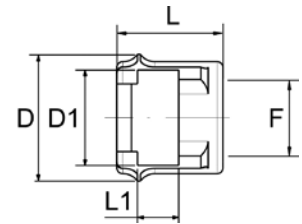

28/B

ATTACCO GIGANTE FILETTATO MASCHIO CON MASCHERINA PORTAGOMMA | LARGE SIZE MALE THREADED CONNECTOR WITH SLEEVE FOR RUBBER HOSE
RACCORD GEANT FILETE MALE AVEC MANCHON PORTE-TUYAU | GROSSER ANSCHLUSS MIT AUSSENGEWINDE UND GUMMISCHLAUCHHALTEVERKLEIDUNG

- Maschio cilindrico ISO 228 (BSPP)
- Ottone Nichelato (UNI EN 12164 CW 614N)
- Mâle cylindrique ISO 228 (BSPP)
- Laiton nickelé (UNI EN 12164 CW 614N)
- Cylindrical male thread - ISO 228 (BSPP)
- Nickel-plated brass (UNI EN 12164 CW 614N)
- Zylindrisches Außengewinde ISO 228 (BSPP)
- Vernickeltes Messing (UNI EN 12164 CW 614N)

COD.	MOD.	F	Di X De	f	P1	P2	L				
AH010823	28/B	3/8M	ø 13x23	ø 8	11	42	61	22	26	5	124
AH010824	28/B	1/2M	ø 13x23	ø 8	11	42	63	22	26	5	128

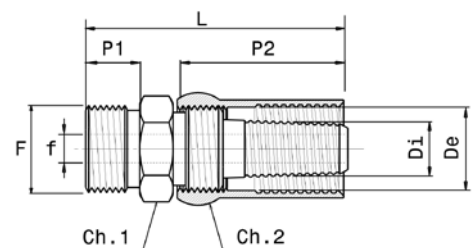



32/A | 32/B | 32/C

DEVIAZIONE A Y MASCHIO CENTRALE | *CENTRAL MALE THREADED Y FITTING* | *JONCTION EN Y MALE CENTRALE* | *Y-ABZWEIGUNG MIT ZENTRALEM AUSSENGEWINDE*

- Maschio conico ISO 7 (BSPT) - DIN 2999 - BS 21
- Femmina cilindrica ISO 228 (BSPP)
- Ottone Nichelato (UNI EN 12165 CW 617N)
- *Mâle conique ISO 7 (BSPT) - DIN 2999 - BS 21*
- *Femelle cylindrique ISO 228 (BSPP)*
- *Laiton nickelé (UNI EN 12165 CW 617N)*
- *Conical male thread ISO 7 (BSPT) - DIN 2999 - BS 21*
- *Cylindrical female thread - ISO 228 (BSPP)*
- *Nickel-plated brass (UNI EN 12165 CW 617N)*
- *Konisches Außengewinde ISO 7 (BSPT) - DIN 2999 - BS 21*
- *Zylindrisches Innengewinde ISO 228 (BSPP).*
- *Vernickeltes Messing (UNI EN 12165 CW 617N)*

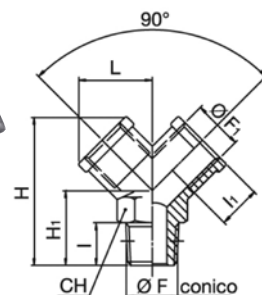

COD.	MOD.	F	F1	I	I1	H1	L	H			
AS030101	32/A	1/4M	1/4F	11	11	20	18	38	17	10	39
AS030102	32/B	3/8M	3/8F	11.5	11.5	22	20.5	42.5	20	10	59
AS030105	32/C	1/2M	1/2F	14	14	27	26.5	53	25	10	108

32/D | 32/E | 32/F

DEVIAZIONE A Y FEMMINA | *CENTRAL FEMALE THREADED Y FITTING* | *JONCTION EN Y FEMELLE* | *Y-ABZWEIGUNG MIT ZENTRALEM INNENGEWINDE*

- Filettatura cilindrica ISO 228 (BSPP)
- Ottone Nichelato (UNI EN 12165 CW 617N)
- *Filetage cylindrique ISO 228 (BSPP)*
- *Laiton nickelé (UNI EN 12165 CW 617N)*
- *Cylindrical Thread - ISO 228 (BSPP)*
- *Nickel-plated brass (UNI EN 12165 CW 617N)*
- *Zylindrisches Gewinde ISO 228 (BSPP).*
- *Vernickeltes Messing (UNI EN 12165 CW 617N)*

COD.	MOD.	F	I	H1	L	H			
AS030501	32/D	1/4F	11	14	18	32	17	10	30
AS030502	32/E	3/8F	11.5	16	20.5	37	20	10	45
AS030503	32/F	1/2F	14	19	26.5	45	25	10	82

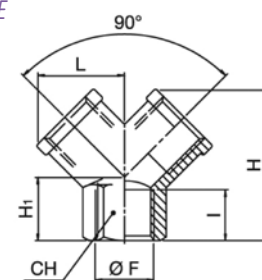

33/M

MANICOTTO DI COLLEGAMENTO FILETTATO FEMMINA | *DOUBLE FEMALE THREADED CONNECTOR* | *MANCHON DE RACCORDEMENT FILETE FEMELLE* | *ANSCHLUSSMUFFE*

- Femmina cilindrico ISO 228 (BSPP)
- Ottone Nichelato (UNI EN 12164 CW 614N)
- *Femelle cylindrique ISO 228 (BSPP)*
- *Laiton nickelé (UNI EN 12164 CW 614N)*
- *Cylindrical female thread - ISO 228 (BSPP)*
- *Nickel-plated brass (UNI EN 12164 CW 614N)*
- *Zylindrisches Außengewinde ISO 228 (BSPP).*
- *Vernickeltes Messing (UNI EN 12164 CW 614N)*

COD.	MOD.	F1	F2	L			
AS030801	33/M	1/8F	1/8F	15	14	10	10
AS030802	33/M	1/4F	1/4F	20	17	10	15
AS030803	33/M	3/8F	3/8F	24	20	10	25
AS030804	33/M	1/2F	1/2F	28	25	10	39
AS030805	33/M	3/4F	3/4F	32	30	10	15
AS030812	33/M	1/8F	1/4F	18	17	10	52
AS030811	33/M	1/8F	3/8F	21	20	10	52
AS030810	33/M	1/8F	1/2F	23	25	10	39
AS030809	33/M	1/4F	3/8F	23	20	10	39
AS030808	33/M	1/4F	1/2F	25	25	10	25
AS030807	33/M	3/8F	1/2F	26	25	10	39
AS030806	33/M	1/2F	3/4F	30	30	10	25

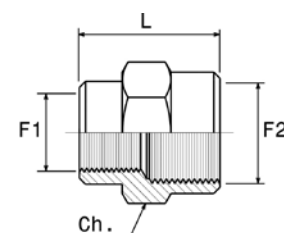
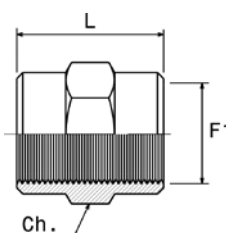



33/N

NIPPOLO DI COLLEGAMENTO FILETTATO MASCHIO | DOUBLE MALE THREADED NIPPLE | MAMELON DE RACCORDEMENT FILETE MALE | ANSCHLUSSNIPPEL

- Filettatura cilindrica ISO 228 (BSPP)
- Ottone Nichelato (UNI EN 12165 CW 617N)
- Filetage cylindrique ISO 228 (BSPP)
- Laiton nickelé (UNI EN 12165 CW 617N)
- Cylindrical Thread - ISO 228 (BSPP)
- Nickel-plated brass (UNI EN 12165 CW 617N)
- Zylindrisches Gewinde ISO 228 (BSPP).
- Vernickeltes Messing (UNI EN 12165 CW 617N)

COD.	MOD.	F1	F2	P1	P2	L			
AS030901	33/N1	1/8M	1/8M	6	6	17	12	10	8
AS030902	33/N2	1/8M	1/4M	6	8	20	14	10	12
AS030903	33/N3	1/8M	3/8M	7	10	22	18	10	19
AS030904	33/N4	1/4M	1/4M	8	8	22	15	10	16
AS030905	33/N5	1/4M	3/8M	8	11	25	18	10	20
AS030906	33/N6	1/4M	1/2M	8	12	28	21	10	32
AS030907	33/N7	3/8M	3/8M	10.5	10.5	27	18	10	26
AS030908	33/N8	3/8M	1/2M	10	12	29	21	10	38
AS030909	33/N9	1/2M	1/2M	12	12	32	21	10	55
AS030910	33/N10	1/2M	3/4M	12	16	36	27	10	63
AS030911	33/N11	3/4M	3/4M	14	14	36	27	10	71

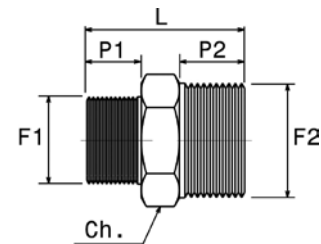

33/R TIPO A | TYPE A

RIDUZIONE MASCHIO/FEMMINA | MALE-FEMALE REDUCING NIPPLE | REDUCTION MALE FEMELLE | REDUZIERUNG AUSSEN-/INNENGEWINDE

- Filettatura cilindrica ISO 228 (BSPP)
- Ottone Nichelato (UNI EN 12165 CW 617N)
- Filetage cylindrique ISO 228 (BSPP)
- Laiton nickelé (UNI EN 12165 CW 617N)
- Cylindrical Thread - ISO 228 (BSPP)
- Nickel-plated brass (UNI EN 12165 CW 617N)
- Zylindrisches Gewinde ISO 228 (BSPP).
- Vernickeltes Messing (UNI EN 12165 CW 617N)

COD.	MOD.	F1	F2	P	L			
AS031205	33/R5	1/4M	1/8F	8	13	15	10	8
AS031209	33/R9	3/8M	1/8F	9	14	19	10	10
AS031210	33/R10	3/8M	1/4F	9	14	19	10	10
AS031213	33/R13	1/2M	1/8F	11.5	17.5	21	10	30
AS031214	33/R14	1/2M	1/4F	11.5	17.5	21	10	25
AS031215	33/R15	1/2M	3/8F	11.5	17.5	21	10	15
AS031217	33/R17	3/4M	1/4F	14.5	20.5	27	10	55
AS031218	33/R18	3/4M	3/8F	14.5	20.5	27	10	50
AS031219	33/R19	3/4M	1/2F	17	23	27	10	40

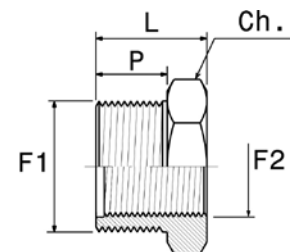

33/R TIPO B | TYPE B

RIDUZIONE MASCHIO FEMMINA | MALE-FEMALE REDUCING NIPPLE | REDUCTION MALE FEMELLE | REDUZIERUNG AUSSEN-/INNENGEWINDE

- Filettatura cilindrica ISO 228 (BSPP)
- Ottone Nichelato (UNI EN 12165 CW 617N)
- Filetage cylindrique ISO 228 (BSPP)
- Laiton nickelé (UNI EN 12165 CW 617N)
- Cylindrical Thread - ISO 228 (BSPP)
- Nickel-plated brass (UNI EN 12165 CW 617N)
- Zylindrisches Gewinde ISO 228 (BSPP).
- Vernickeltes Messing (UNI EN 12165 CW 617N)

COD.	MOD.	F1	F2	P1	P2	L			
AS031201	33/R1	1/8M	1/8F	6	5.5	16	14	10	16
AS031202	33/R2	1/8M	1/4F	6	8.5	20	17	10	15
AS031203	33/R3	1/8M	3/8F	7	10.5	21.5	20	10	19
AS031204	33/R4	1/8M	1/2F	9	14.5	27	24	10	32
AS031206	33/R6	1/4M	1/4F	8	9	21	17	10	17
AS031207	33/R7	1/4M	3/8F	9	10	24	20	10	17
AS031208	33/R8	1/4M	1/2F	9	13.5	27	24	10	32
AS031211	33/R11	3/8M	3/8F	9	10.5	23.5	20	10	25
AS031212	33/R12	3/8M	1/2F	9	13.5	27	24	10	35
AS031216	33/R16	1/2M	1/2F	11	13	29	24	10	40
AS031220	33/R20	3/4M	3/4F	15.5	15.5	36.5	30	10	74

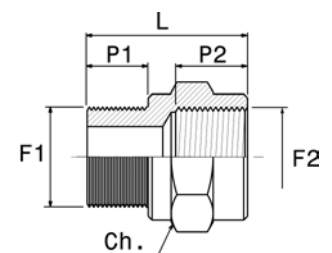



33/T

TAPPO FILETTATO MASCHIO | MALE THREADED PLUG | BOUCHON FILETE MALE | VERSCHLUSS MIT AUSSENGEWINDE

- Filettatura cilindrica ISO 228 (BSPP)
- Ottone Nichelato (UNI EN 12165 CW 617N)
- Filetage cylindrique ISO 228 (BSPP)
- Laiton nickelé (UNI EN 12165 CW 617N)
- Cylindrical Thread - ISO 228 (BSPP)
- Nickel-plated brass (UNI EN 12165 CW 617N)
- Zylindrisches Gewinde ISO 228 (BSPP).
- Vernickeltes Messing (UNI EN 12165 CW 617N)

COD.	MOD.	F	P	L			
AS031301	33/T	1/8M	6	11	12	10	6
AS031302	33/T	1/4M	8	13	15	10	11
AS031303	33/T	3/8M	9	14	19	10	18
AS031304	33/T	1/2M	10	16.5	22	10	32
AS031305	33/T	3/4M	12	19.5	27	10	58

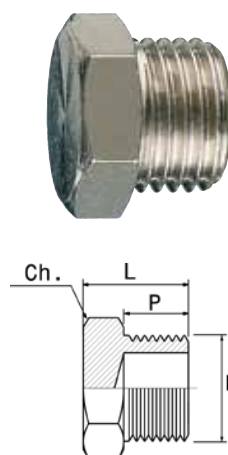

33/TS

TAPPO FILETTATO MASCHIO CONICO A SCOMPARSITA | MALE THREADED PLUG | BOUCHON FILETE MALE | VERSCHLUSS MIT AUSSENGEWINDE

- Maschio conico ISO 7 (BSPT) - DIN 2999 - BS 21
- Ottone Nichelato (UNI EN 12165 CW 617N)
- Mâle conique ISO 7 (BSPT) - DIN 2999 - BS 21
- Laiton nickelé (UNI EN 12165 CW 617N)
- Conical male thread ISO 7 (BSPT) - DIN 2999 - BS 21
- Nickel-plated brass (UNI EN 12165 CW 617N)
- Konisches Außengewinde ISO 7 (BSPT) - DIN 2999 - BS 21.
- Vernickeltes Messing (UNI EN 12165 CW 617N)

COD.	MOD.	F	H			
AH0313301A	33/TS	1/8M	7.5	5	10	3
AH0313302A	33/TS	1/4M	10	6	10	8
AH0313303A	33/TS	3/8M	11	8	10	15
AH0313304A	33/TS	1/2M	13	10	10	26

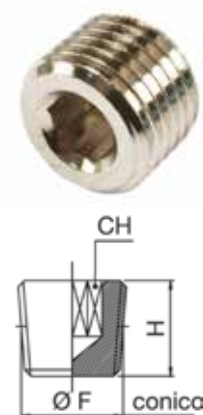

33/TF

TAPPO FILETTATO FEMMINA | MALE THREADED PLUG | BOUCHON FILETE MALE | VERSCHLUSS MIT AUSSENGEWINDE

- Filettatura cilindrica ISO 228 (BSPP)
- Ottone Nichelato (UNI EN 12165 CW 617N)
- Filetage cylindrique ISO 228 (BSPP)
- Laiton nickelé (UNI EN 12165 CW 617N)
- Cylindrical Thread - ISO 228 (BSPP)
- Nickel-plated brass (UNI EN 12165 CW 617N)
- Zylindrisches Gewinde ISO 228 (BSPP).
- Vernickeltes Messing (UNI EN 12165 CW 617N)

COD.	MOD.	F	I	H			
AH0313401A	33/T	1/8F	8	10	14	10	10
AH0313402A	33/T	1/4F	11	13.5	17	10	17
AH0313403A	33/T	3/8F	11.5	14	20	10	20
AH0313404A	33/T	1/2F	14	16.5	24	10	32
AH0313405A	33/T	3/4F	16	18.5	30	5	54
AH0313406A	33/T	1"F	16.5	20	38	5	100

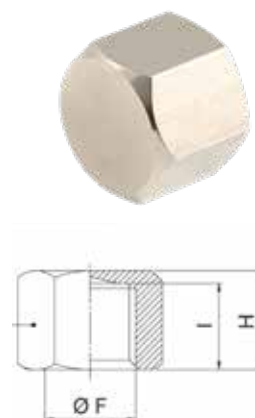



33/NG

NIPPOLO DI COLLEGAMENTO GIREVOLE FILETTATO MASCHIO | *DOUBLE MALE THREADED SWIVELLING NIPPLE*
 MAMELON DE RACCORDEMENT PIVOTANT FILETE MALE | *DREHBARER VERBINDUNGSNIPPEL MIT AUSSENGEWINDE*

- Gas cilindrica ISO 228 (BSPP)
- Ottone Nichelato (UNI EN 12164 CW 614N)
- Guarnizione in gomma NBR
- Gaz cylindrique ISO 228 (BSPP)
- Laiton nickelé (UNI EN 12164 CW 614N)
- Joint en caoutchouc NBR
- Cylindrical Gas Thread - ISO 228 (BSPP)
- Nickel-plated brass (UNI EN 12164 CW 614N)
- NBR washers
- Zylindrisches Gasgewinde - ISO 228 (BSPP).
- Vernickeltes Messing (UNI EN 12164 CW 614N)
- NBR-Dichtungen

COD.	MOD.	F1	F2	P1	P2	L			
AH012750	33/NG 4	1/4	1/4	9.5	9.5	29	14	10	38

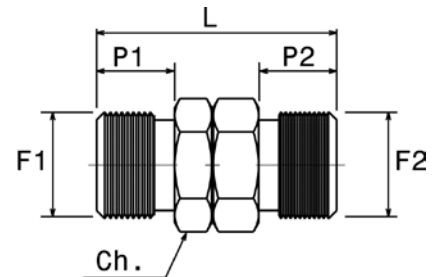

33/N3P

NIPPOLO DI COLLEGAMENTO 3 PEZZI FILETTATO MASCHIO | *3 PIECES MALE THREADED CONNECTION NIPPLE*
 MAMELON DE RACCORDEMENT 3 PIECES FILETE MALE | *VERBINDUNGSNIPPEL 3 STÜCK MIT AUSSENGEWINDE*

- Maschio conico ISO 7 (BSPT) - DIN 2999 - BS 21
- Ottone (UNI EN 12164 CW 614N)
- Mâle conique ISO 7 (BSPT) - DIN 2999 - BS 21
- Laiton (UNI EN 12164 CW 614N)
- Conical male thread ISO 7 (BSPT) - DIN 2999 - BS 21
- Brass (UNI EN 12164 CW 614N)
- Konisches Außengewinde ISO 7 (BSPT) - DIN 2999 - BS 21
- Messing (UNI EN 12164 CW 614N)

COD.	MOD.	F1	F2	P1	P2	L			
AH012751	33/N3P	1/4M	1/4M	12	12	34	19	10	38
AH012752	33/N3P	3/8M	3/8M	12.5	14	37.5	22	10	61
AH012753	33/N3P	1/2M	1/2M	17	16.5	48.5	27	10	85
AH012754	33/N3P	3/8M	1/2M	12.5	14.5	44	27	10	75
AH012755	33/N3P	1/4M	3/8M	12	14	38	22	10	55
AH012758	33/N3P	1/8M	1/4M	12.5	12	35	19	10	37

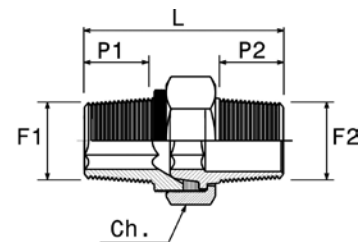



ANI SPA
Via Arzignano, 190
36072 CHIAMPO (VI) ITALY
tel. +39 0444 420888
fax +39 0444 420620
ani@ani.it

www.ani.it